

ROLLON[®]
BY TIMKEN

Hegra Rail

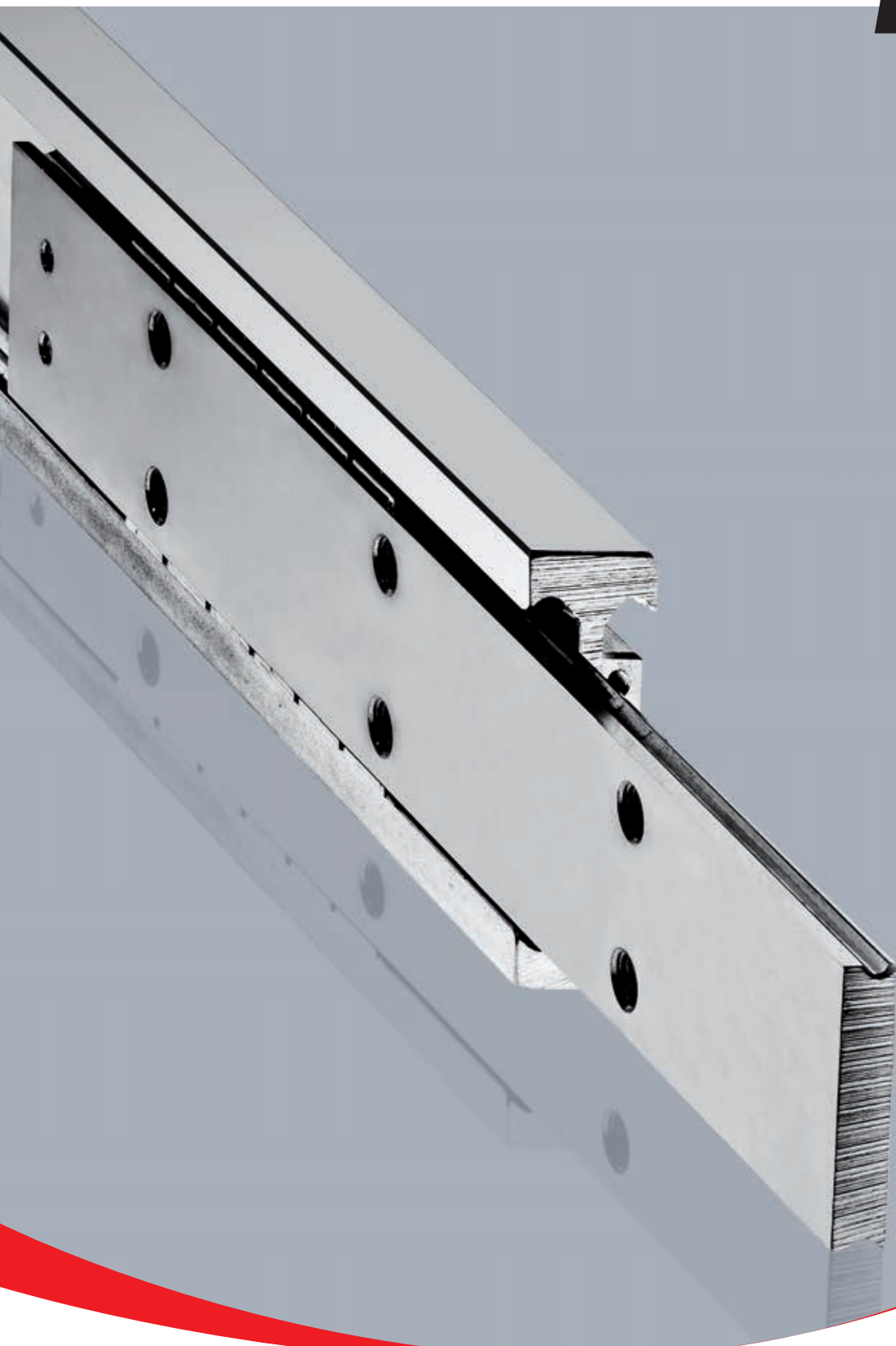

Product explanation



> Partial and full extension guides of different types



Fig. 1

The Hegra Rail product family consists of five product categories: partial, fully extending, overextending and heavy-duty rails as well as S-profiles. Different versions in the single categories, such as design or materials, also provide for increased customer benefits.

The most important characteristics:

- High load capacity and minimal deflection
- Different versions and materials
- Compact design
- Lightweight; smooth operation
- Long life
- High functional reliability

Preferred applications:

- Rail vehicles (maintenance and battery compartments)
- Motor vehicle technology
- Construction and machine technology
- Special purpose machinery

Partial extension guides

Partial extension guides with a stroke of more than 50 % of the closed telescoping length, consisting of one guide rail and one slider. The high system rigidity is achieved here in combination with the connection construction.



Fig. 2

Full extension guides

Full extension guides with strokes of about 100 % of the closed length consisting of three elements in different designs and sizes.



Fig. 3

Overextending guides

Overextending guides with a stroke of up to 200 % of the closed telescoping length. The use of intermediate elements with a high moment of inertia achieves excellent system rigidity and a high load capacity in fully extended systems.



Fig. 4

Heavy load extension guides

Full extension guides with strokes of about 100 % of the length consist of a solid, double T-shaped intermediate element and the two corresponding sliders. This full extension guide was specially designed for extremely heavy loads with minimal deflection and high system rigidity.



Fig. 5

S-profiles

Full extension guides with strokes of about 100 % of the closed length consisting of two guide rails and one S-shaped intermediate element. The advantages of the full extension guide are high rigidity and a compact design.

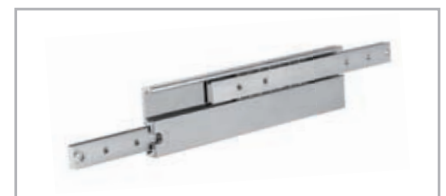

Fig. 6

Overview product cross sections



> Partial extension guides

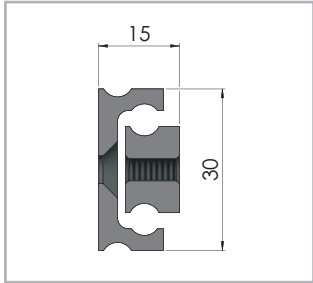

Fig. 7

HTT030

Load capacities p. HR-7

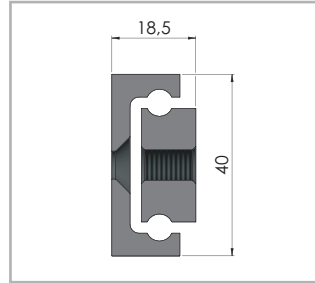

Fig. 8

HTT040

Load capacities p. HR-8

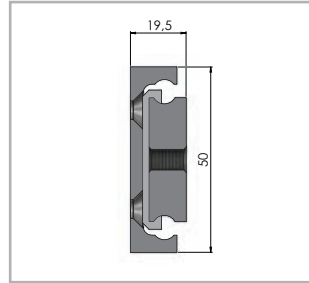

Fig. 9

HTT050

Load capacities p. HR-9

> Full extension guides

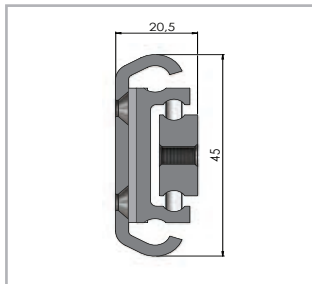

Fig. 10

HVC045

Load capacities p. HR-11

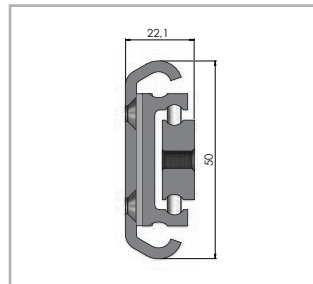

Fig. 11

HVC050

Load capacities p. HR-12

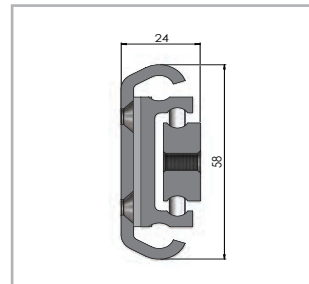

Fig. 12

HVC058

Load capacities p. HR-13

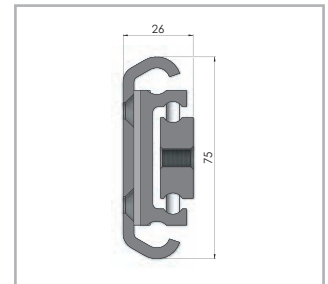

Fig. 13

HVC075

Load capacities p. HR-14

> Overextending guides

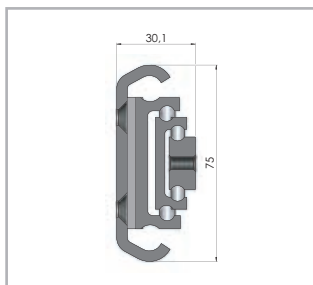

Fig. 14

H1C075

Load capacities p. HR-16

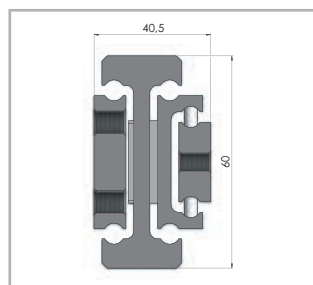

Fig. 15

H1T060

Load capacities p. HR-18

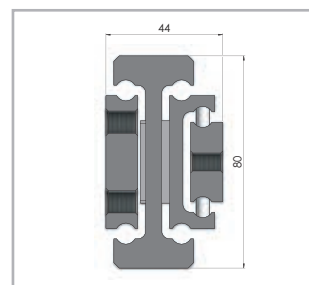

Fig. 16

H1T080

Load capacities p. HR-19

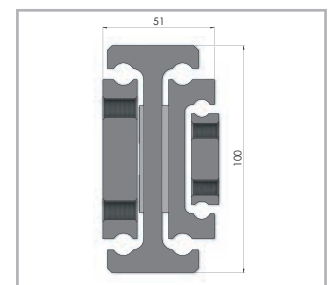

Fig. 17

H1T100

Load capacities p. HR-20

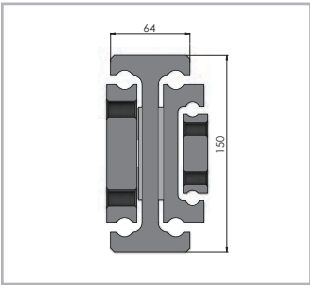

Fig. 18

H1T150

Versions are available on request
Load capacities p. HR-21

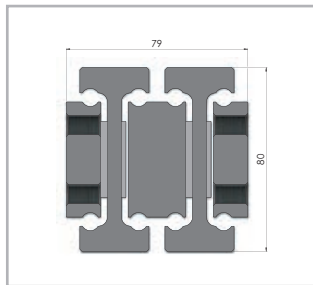

Fig. 19

H2H080

Load capacities p. HR-22

> **Heavy load extension guides**

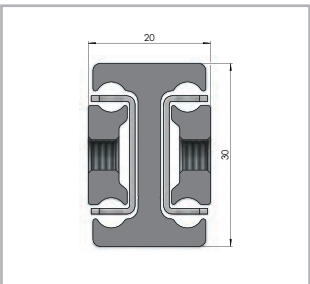

Fig. 20

LTH30

Load capacities p. HR-24

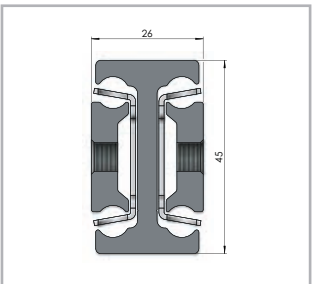

Fig. 21

LTH45

Load capacities p. HR-27

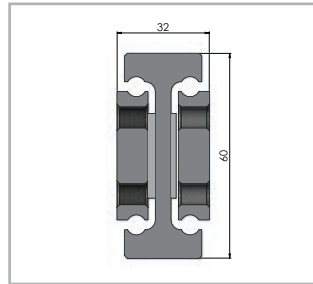

Fig. 22

HGT060

Load capacities p. HR-31

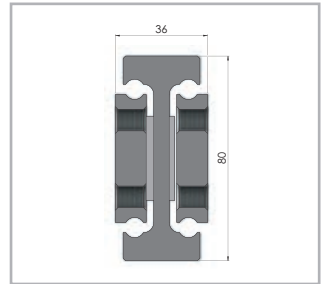

Fig. 23

HGT080

Load capacities p. HR-32

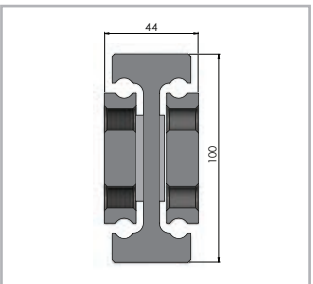

Fig. 24

HGT100

Load capacities p. HR-33

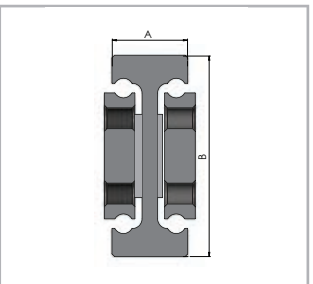

Fig. 25

HGT120, HGT150, HGT200, HGT240

Versions are available on request
Load capacities p. HR-33

- HGT120: A = 44, B = 120
- HGT 150: A = 56, B = 150
- HGT 200: A = 72, B = 200
- HGT 240: A = 74, B = 240

> **S-profiles**

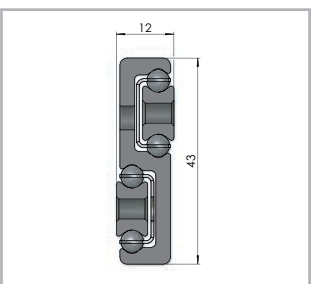

Fig. 26

LTF44

Load capacities p. HR-35

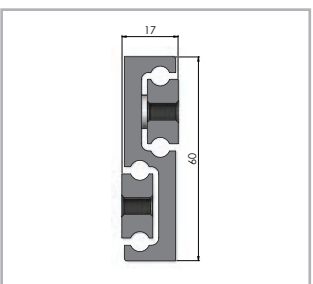

Fig. 27

HGS060

Load capacities p. HR-37

Technical data

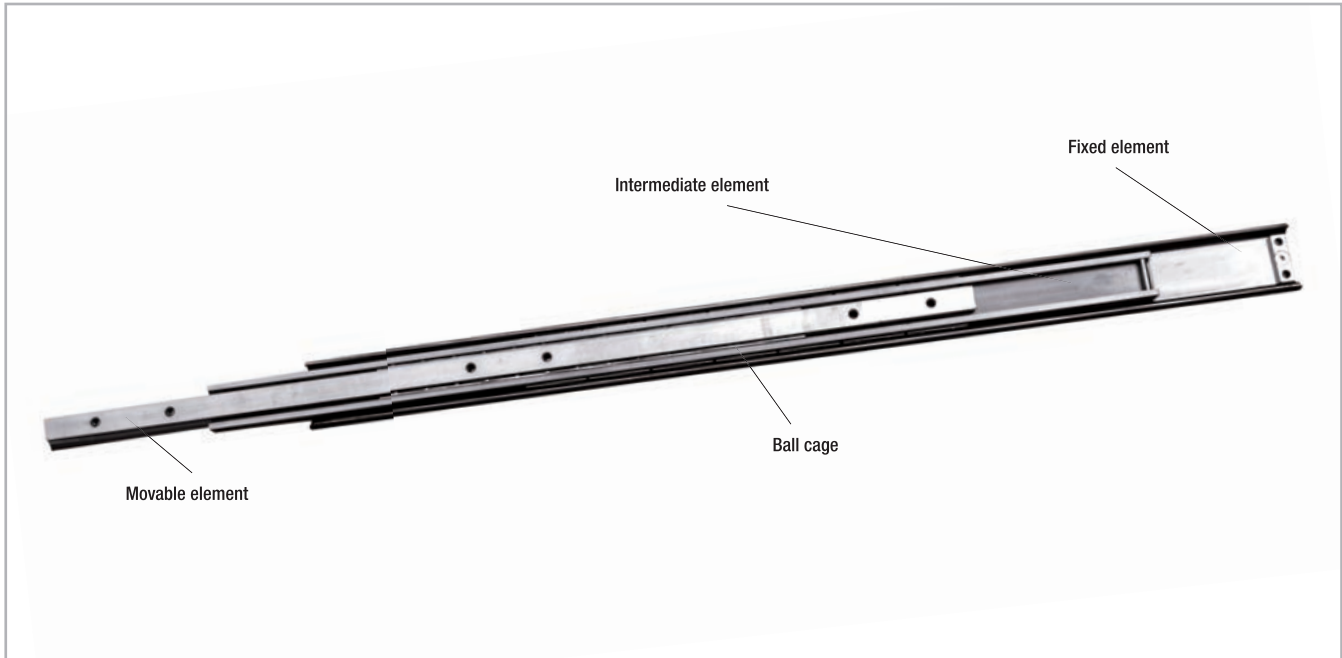

Fig. 28

Performance characteristics:

- Temperature range: -20 °C to +170 °C (-4 °F to +338 °F)
(in exceptions also -30 °C to +250 °C (-22 °F to +482 °F))
- Max. operating speed 0.8 m/s (depending on the application)
- Different materials and anti-corrosion coatings are available
- Special solutions, such as locking mechanisms, catches, damping elements or are available on request

Attention!

The load capacity for aluminum is 40 % and for stainless steel 60 % of the stated values, if available in this material variant.

Notes:

- Horizontal movement installation is recommended
- Vertical movement installation on request
- Special strokes on request
- All load capacities refer to one telescopic pair
- Mounting screws with a strength class of 10.9 must be used for all telescopic rails
- Internal stops are provided to stop the sliders when not under load and the ball cage. Please use external stops as limit stops for a system under load
- Not all accessories (interlocks, damping, drive disk, snap) can be combined with each other. Please contact our technical service.
- For models HGT with locking please observe right or left side use.
- Temperature range: LTH
-20 °C to +170 °C (-4 °F to +338 °F)
- Temperature range: LTH ...S
-20 °C to +50 °C (-4 °F to +122 °F)
- Telescopic guides made of aluminum or stainless steel are standard without greasing. If a greasing is desired, it must be stated separately at the order.
- Please note eventually dimensional variations in use of stainless steel. Please contact our technical service.

Load capacities and dimensions

> HTT030

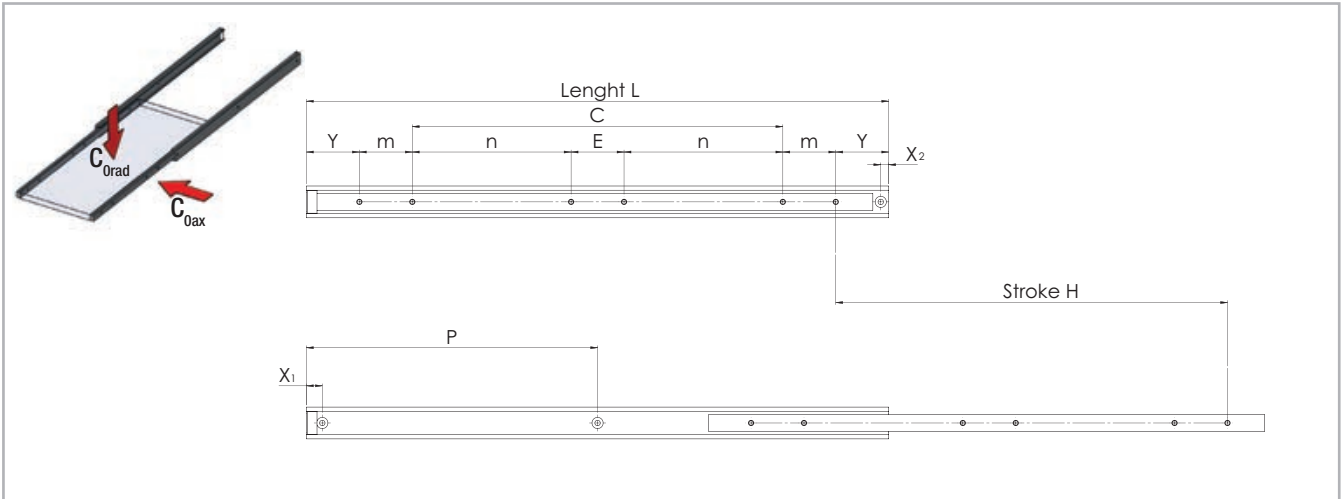

All dimensions are indicated in mm

Fig. 29

Type	Size	Length L [mm]	Stroke H [mm]	Load capacity per pair		X1*	X2	Y	m	n	E	C	P	Number of holes
				C _{Orad} [N]	C _{Oax} [N]									
HTT	30	250	130	1100	on request	15	7.5	50	50	-	-	50	125	4
		300	180	1200								100	150	
		350	230	1150								150	175	
		400	260	1100								200	200	
		450	310	1050								250	225	
		500	340	1000								300	250	
		550	370	950								150	275	6
		600	400	900								175	300	
		650	430	850								200	325	
		700	460	800								225	350	
		750	490	750								250	375	
		800	520	700								275	400	
		850	550	650								300	425	
		900	600	600								325	450	
		950	630	550								350	475	
1000	660	500	375	500										

The load capacity for aluminum is 40% and for stainless steel 60% of the stated values, if available in this material variant (see Technical features overview).

* For double-sided stroke the dimension X1=7,5mm

Tab. 1

> **HTT040**

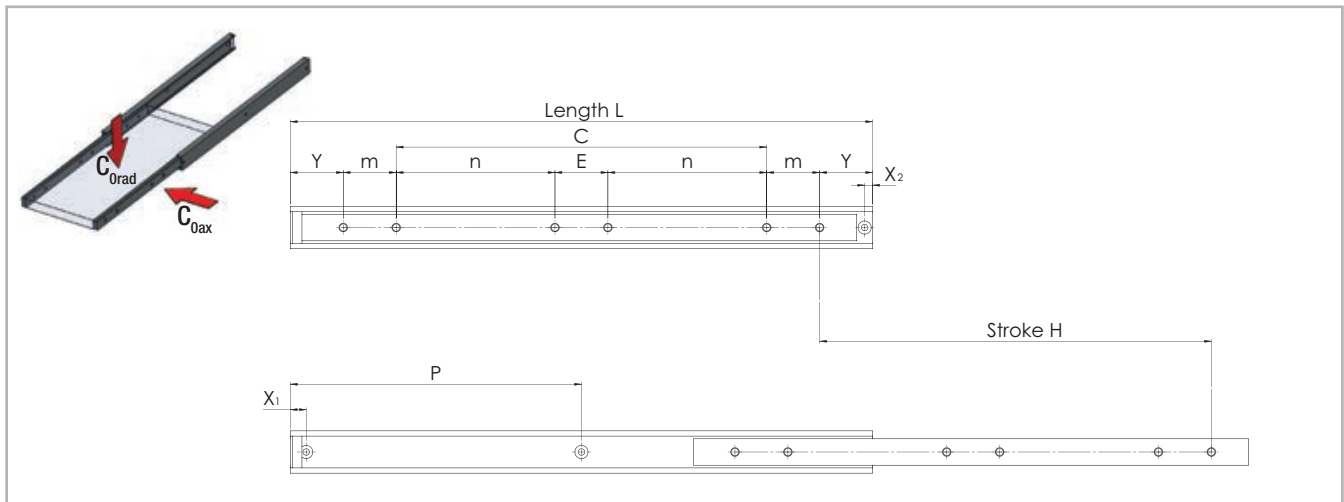

All dimensions are indicated in mm

Fig. 30

Type	Size	Length L [mm]	Stroke H [mm]	Load capacity per pair		X1*	X2	Y	m	n	E	C	P	Number of holes
				C _{Orad} [N]	C _{Oax} [N]									
HTT	40	250	130	2100	on request	15	7.5	50	50	-	-	50	125	4
		300	180	2250								100	150	
		350	230	2350								150	175	
		400	260	2450								200	200	
		450	310	2550								250	225	
		500	340	2500								300	250	
		550	370	2450								150	275	6
		600	400	2400								175	300	
		650	430	2350								200	325	
		700	460	2300								225	350	
		750	490	2250								250	375	
		800	520	2150								275	400	
		850	550	2050								300	425	
		900	600	1950								325	450	
		950	630	1800								350	475	
		1000	660	1650								375	500	

The load capacity for aluminum is 40% and for stainless steel 60% of the stated values, if available in this material variant (see Technical features overview).

* For double-sided stroke the dimension X1=7,5mm

Tab. 2

> HTT050

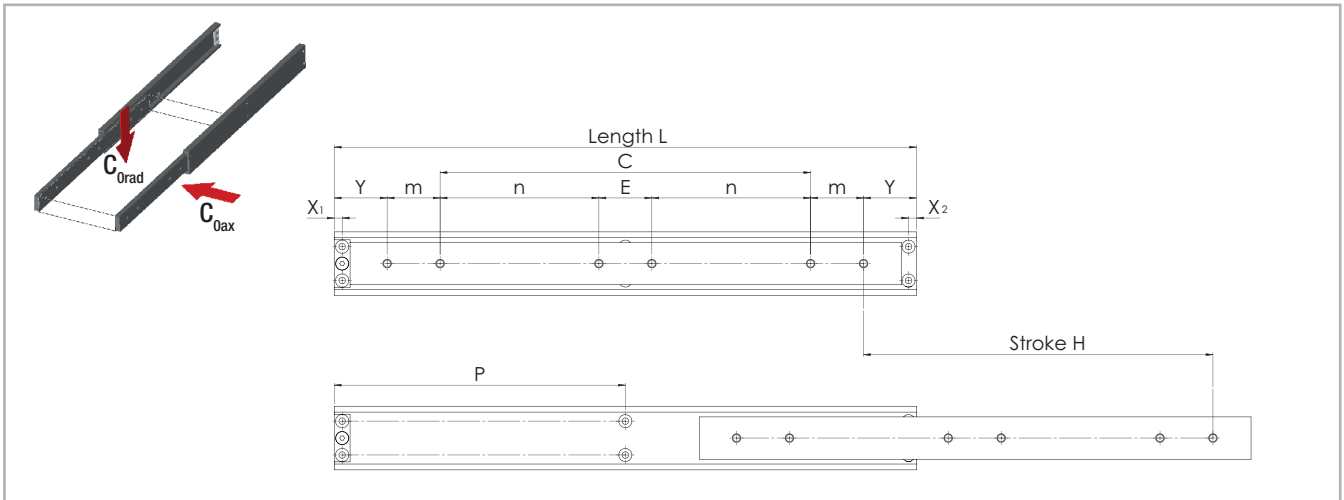

All dimensions are indicated in mm

Fig. 31

Type	Size	Length L [mm]	Stroke H [mm]	Load capacity per pair		X1*	X2	Y	m	n	E	C	P	Number of holes
				C _{Orad} [N]	C _{Oax} [N]									
HTT	50	300	180	2500	on request	15	7.5	50	50	-	-	100	150	4
		350	230	2600								150	175	
		400	260	2700								200	200	
		450	310	2800								250	225	
		500	340	2900								300	250	6
		550	370	2850								150	275	
		600	400	2800								175	300	
		650	430	2700								200	325	
		700	460	2600								225	350	
		750	490	2500								250	375	
		800	520	2400								275	400	
		850	550	2300								300	425	
		900	600	2200								325	450	
		950	630	2100								350	475	
		1000	660	2000								375	500	
		1100	700	1850								425	525	
1200	760	1650	475	550										

The load capacity for aluminum is 40% and for stainless steel 60% of the stated values, if available in this material variant (see Technical features overview).
 * For double-sided stroke the dimension X1=7,5mm

Tab. 3

> **HTT**

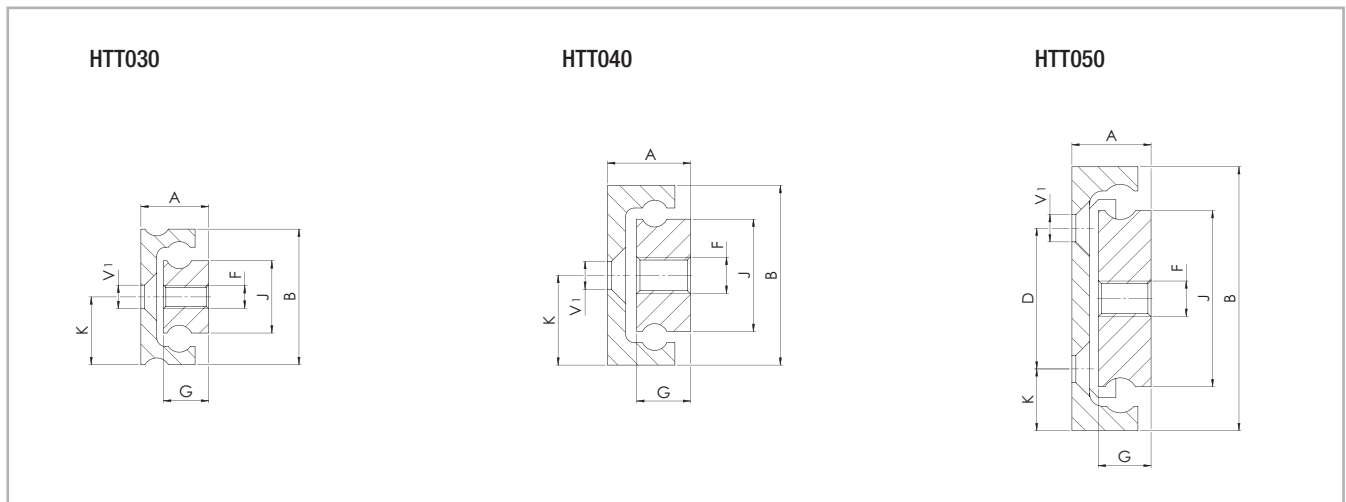

All dimensions are indicated in mm
 * Mounting holes (V) for countersunk screws according to DIN 7991/ISO 10642

Fig. 32

Type	Size	A	B	J	G	K	D	D1	F	V1	Weight per single guide [kg/m]
HTT	30	15	30	16	10	15	-	-	M6	M5	2.4
	40	18.5	40	25	12	20	-	-	M8	M6	4.3
	50	19.5	50	30	12.5	25	25	5.6			

Tab. 4

> HVC045, HVC050, HVC058, HVC075

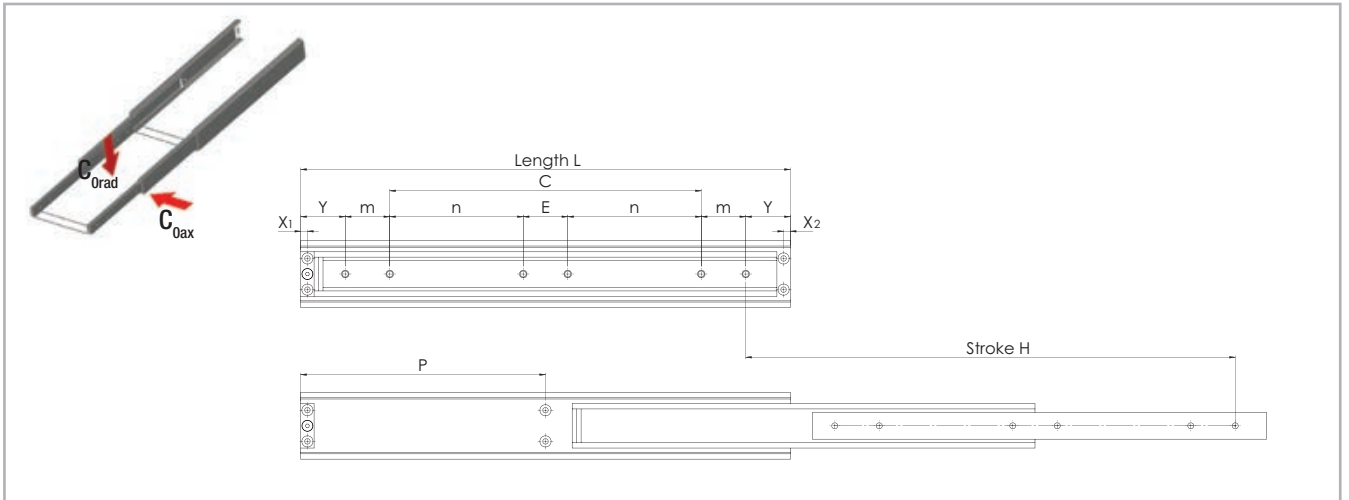

All dimensions are indicated in mm

Fig. 33

Type	Size	Length L [mm]	Stroke H [mm]	Load capacity per pair		X1	X2	Y	m	n	E	C	P	Number of holes
				C _{0rad} [N]	C _{0ax} [N]									
HVC	45	300	300	1150	on request	7.5	7.5	50	50			100		4
		350	350	1200								150		
		400	400	1200								200		
		450	450	1150								250		
		500	500	1150								300		
		550	550	1100								-	275	
		600	600	1050								150	300	
		650	650	1000								175	325	
		700	700	950								200	350	
		750	750	900								225	325	
		800	800	850								250	400	
		850	850	800								275	425	
		900	900	750								300	450	
		950	950	700								325	475	
		1000	1000	650								350	500	
		1100	1100	500								375	50	
1200	1200	400	425	600										
				475										

The load capacity for aluminum is 40% and for stainless steel 60% of the stated values, if available in this material variant (see Technical features overview).

Tab. 5

4 Load capacities and dimensions

Type	Size	Length L [mm]	Stroke H [mm]	Load capacity per pair		X1	X2	Y	m	n*	E*	C	P	Number of holes	
				C _{Grad} [N]	C _{Oax} [N]										
HVC	50	300	300	1400	on request	7.5	7.5	50	50	-	-	100	-	4	
		350	350	1450								150			
		400	400	1500								200			
		450	450	1450								250			
		500	500	1400								300			
		550	550	1350								150			275
		600	600	1300								175			300
		650	650	1250								200			325
		700	700	1200								225			350
		750	750	1150								250			325
		800	800	1100								275			400
		850	850	1050								300			425
		900	900	1000								325			450
		950	950	950								350			475
		1000	1000	900								375			500
		1100	1100	800								425			550
		1200	1200	700								475			600
		1300	1300	600								525			650
		1400	1400	500								575			700
		1500	1500	400								625			750

The load capacity for aluminum is 40 % and for stainless steel 60 % of the stated values, if available in this material variant (see Technical features overview).

*When using full telescopes with interlocks in the open state (VO) or with interlocks open and closed (VB) the following measures change:
n reduces by 35 mm - E increases to 120 mm.

Tab. 6

Type	Size	Length	Stroke	Load capacity per pair		X1	X2	Y	m	n*	E*	C	P	Number of holes	
				C _{Orad} [N]	C _{Oax} [N]										
HVC	58	300	300	2000	on request	7.5	7.5	50	50	-	-	100	-	4	
		350	350	2050								150			
		400	400	2100								200			
		450	450	2050								250			
		500	500	2000								300			
		550	550	1950								150		275	6
		600	600	1900								175		300	
		650	650	1850								200		325	
		700	700	1800								225		350	
		750	750	1750								250		325	
		800	800	1700								275		400	
		850	850	1650								300		425	
		900	900	1600								325		450	
		950	950	1500								350		475	
		1000	1000	1450								375		500	
		1100	1100	1350								425		550	
		1200	1200	1250								475		600	
		1300	1300	1150								525		650	
		1400	1400	1050								575		700	
		1500	1500	1000								625		750	

The load capacity for aluminum is 40% and for stainless steel 60% of the stated values, if available in this material variant (see Technical features overview).

*When using full telescopes with interlocks in the open state (VO) or with interlocks open and closed (VB) the following measures change: n reduces by 35 mm - E increases to 120 mm.

Tab. 7

H
R

4 Load capacities and dimensions

Type	Size	Length	Stroke	Load capacity per pair		X1	X2	Y	m	n*	E*	C	P	Number of holes	
				C _{Grad} [N]	C _{Max} [N]										
HVC	75	300	300	3200	on request	7.5	7.5	50	50	-	-	100	-	4	
		350	350	3250								150			
		400	400	3300								200			
		450	450	3250								250			
		500	500	3200								300			
		550	550	3150								150			275
		600	600	3100								175			300
		650	650	3050								200			325
		700	700	3000								225			350
		750	750	2950								250			325
		800	800	2900								275			400
		850	850	2850								300			425
		900	900	2800								325			450
		950	950	2750								350			475
		1000	1000	2700								375			500
		1100	1100	2600								425			550
		1200	1200	2500								475			600
		1300	1300	2350								525			650
		1400	1400	2200								575			700
		1500	1500	2050								625			750
1600	1600	1900	675	800											
1700	1700	1750	725	50											
1800	1800	1600	775	900											
1900	1900	1450	825	950											
2000	2000	1300	875	1000											

The load capacity for aluminum is 40 % and for stainless steel 60 % of the stated values, if available in this material variant (see Technical features overview).

*When using full telescopes with interlocks in the open state (VO) or with interlocks open and closed (VB) the following measures change:
n reduces by 35 mm - E increases to 120 mm.

Tab. 8

> HVC

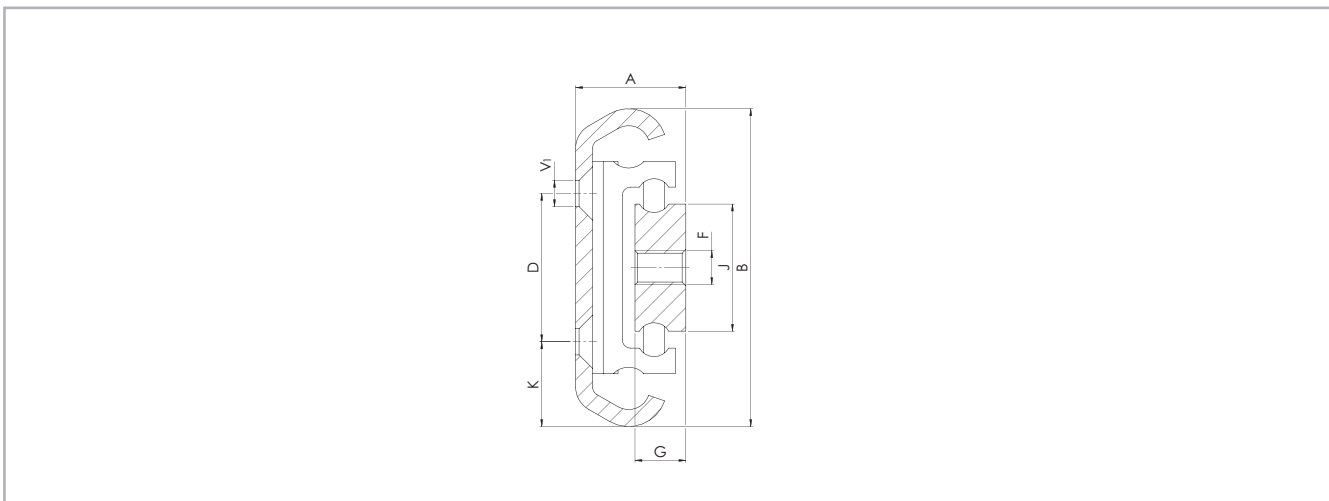

Fig. 34

All dimensions are indicated in mm
 V¹ Mounting holes (V) for countersunk screws according to DIN 7991/ISO 10642

Type	Size	A	B	J	G	K	D	F	V1	Weight per single guide [kg/m]
HVC	45	20.5	45	16	10	11.5	22	M6	M5	4.00
	50	22.1	50	20	12	14				5.10
	58	24	58	25		20	13	32	M8	M6
	75	26	75	30	20		35	9.30		

Tab. 9

H
R

H1C075

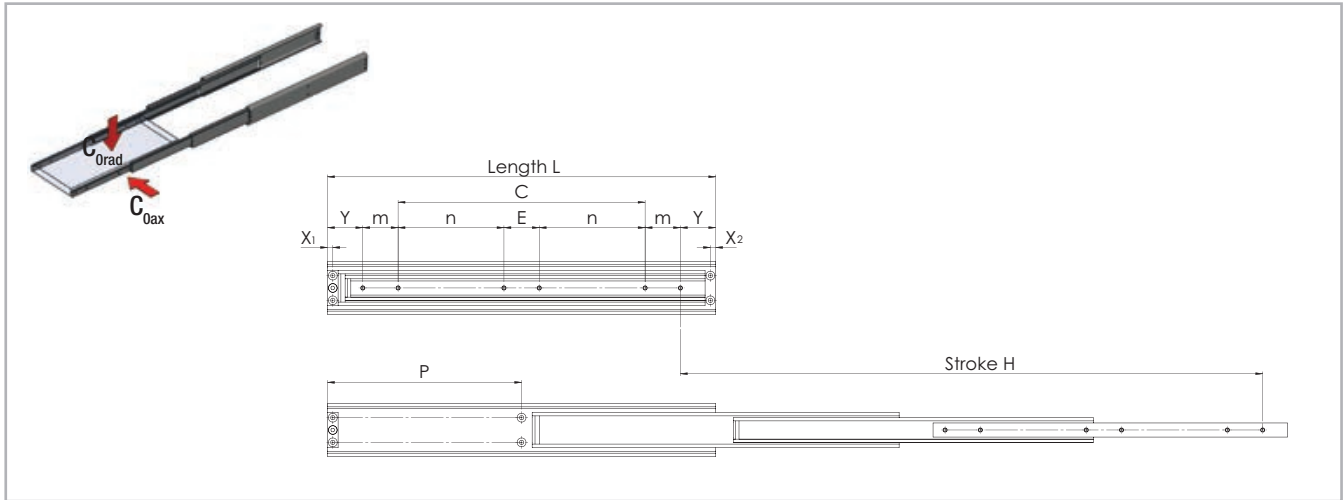

All dimensions are indicated in mm

Fig. 35

Type	Size	Length	Stroke	Load capacity per pair C_{Orad} [N]	X1	X2	Y	m	n	E	C	P	Number of holes
		L [mm]	H [mm]										
H1C	75	300	450	1200	7.5	7.5	50	50	-	50	100	-	4
		350	525	1250							150		
		400	600	1300							200		
		450	675	1350							250		
		500	750	1300							300		
		550	825	1200							150	275	6
		600	900	1150							175	300	
		650	975	1100							200	325	
		700	1050	1050							225	350	
		750	1125	1000							250	325	
		800	1200	950							275	400	
		850	1275	900							300	425	
		900	1350	850							325	450	
		950	1425	800							350	475	
		1000	1500	750							375	500	
		1100	1650	650							425	550	
		1200	1800	550							475	600	
		1300	1950	450							525	650	
		1400	2100	350							575	700	
		1500	2250	200							625	750	

The load capacity for aluminum is 40% and for stainless steel 60% of the stated values, if available in this material variant (see Technical features overview).

Tab. 10

> H1C075

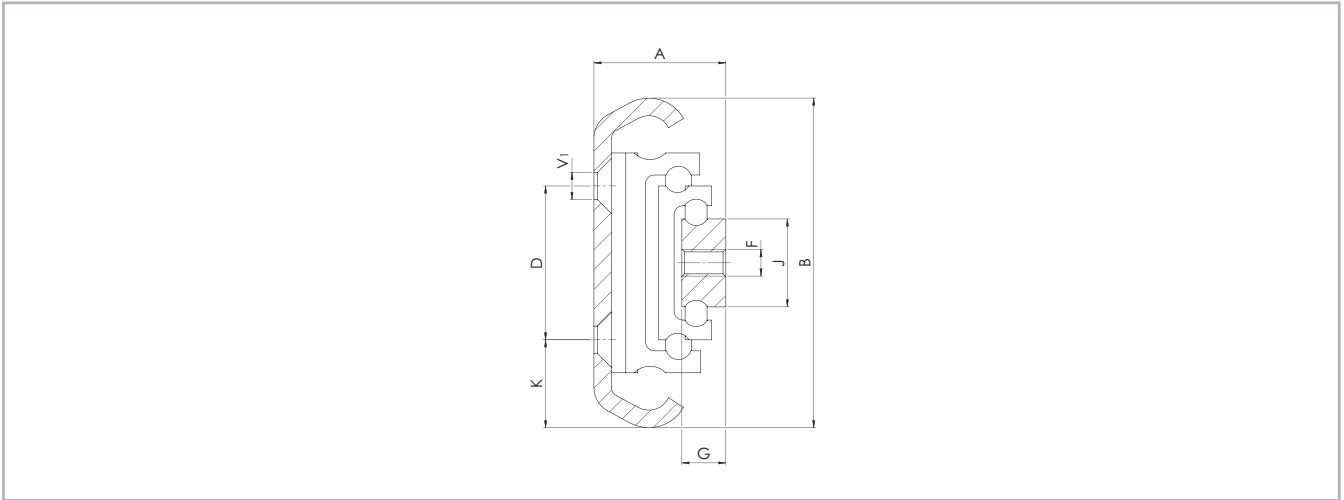

Fig. 36

All dimensions are indicated in mm
 V¹ Mounting holes (V) for countersunk screws according to DIN 7991/ISO 10642

Type	Size	A	B	J	G	K	D	F	V1	Weight per single guide [kg/m]
H1C	75	30	75	20	10	20	35	M6	M6	8.60

Tab. 11

> H1T060, H1T080

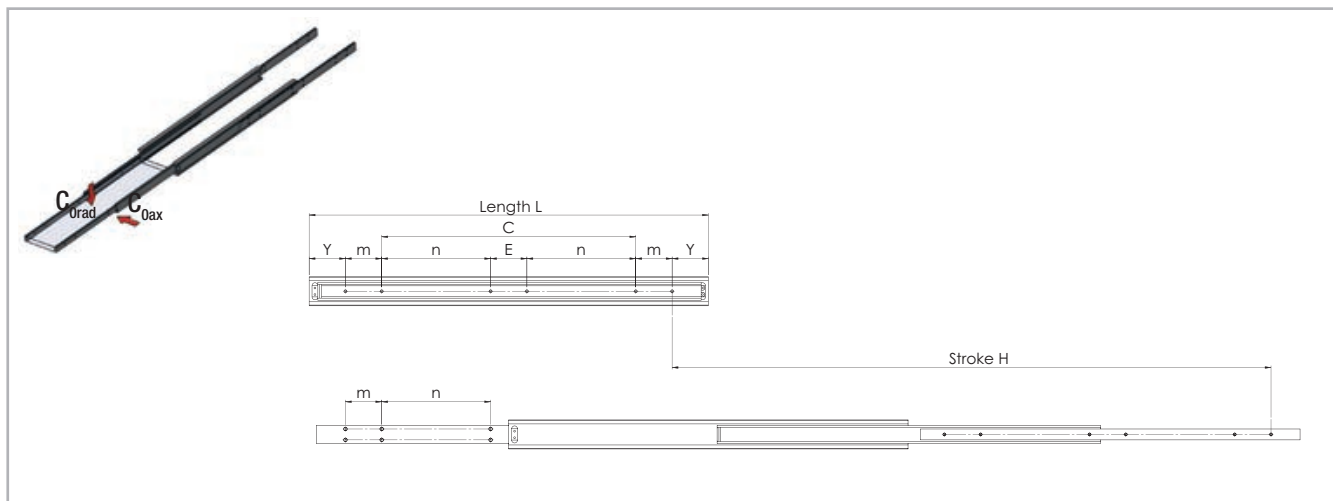

All dimensions are indicated in mm

Fig. 37

Type	Size	Length L [mm]	Stroke H [mm]	Load capacity per pair C_{Orad} [N]	Y	m	n	E	C	Number of holes		
										M6	M8	
H1T	60	300	450	2400	50	50				100	8	4
		350	525	2500						150		
		400	600	2550						200		
		450	675	2600						250		
		500	750	2600						300		
		550	825	2550			150	50	-	-	12	6
		600	900	2500			175					
		650	975	2450			200					
		700	1050	2400			225					
		750	1125	2350			250					
		800	1200	2300			275					
		850	1275	2250			300					
		900	1350	2200			325					
		950	1425	2150			350					
		1000	1500	2100			375					
		1100	1650	2000			425					
		1200	1800	1850			475					
		1300	1950	1700			525					
		1400	2100	1550			575					
		1500	2250	1400			625					

The load capacity for aluminum is 40% and for stainless steel 60% of the stated values, if available in this material variant (see Technical features overview).

Tab. 12

Type	Size	Length		Stroke	Load capacity per pair C_{0rad} [N]	Y	m	n	E	C	Number of holes	
		L [mm]	H [mm]								M8	M10
H1T	80	500	750	3100	100	100					4	8
		550	825	3150								
		600	900	3200								
		650	975	3150								
		700	1050	3100								
		750	1125	3000								
		800	1200	2900								
		850	1275	2800								
		900	1350	2700								
		950	1425	2600								
		1000	1500	2500								
		1100	1650	2280								
		1200	1800	2060								
		1300	1950	1840								
		1400	2100	1620								
		1500	2250	1400								
							300	100	-	6	12	
						350						
						400						
						450						
							500					

The load capacity for aluminum is 40% and for stainless steel 60% of the stated values, if available in this material variant (see Technical features overview).

Tab. 13

> H1T100, H1T150

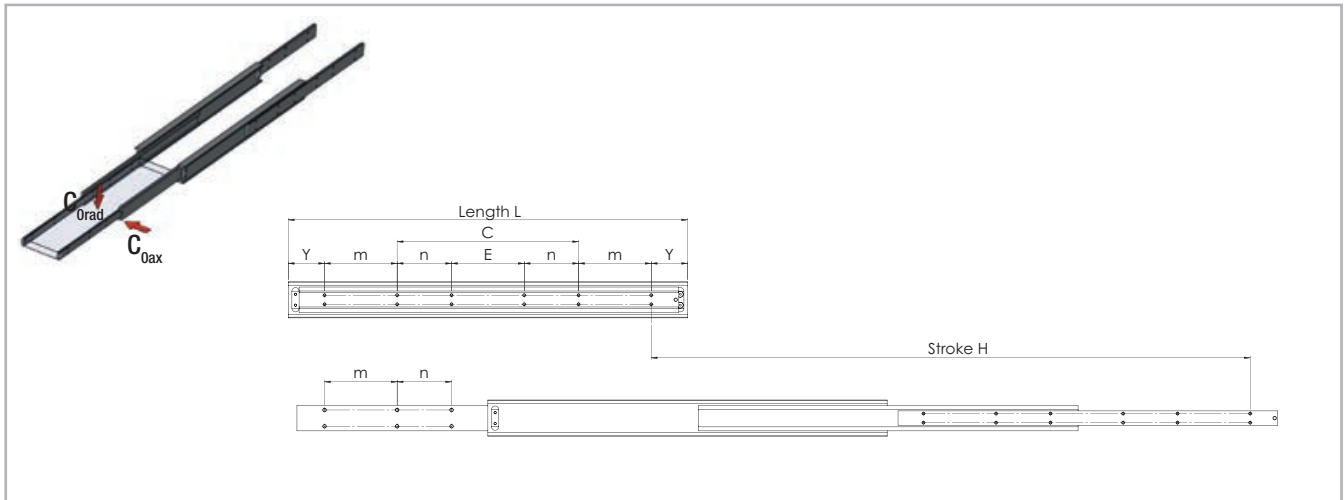

All dimensions are indicated in mm

Fig. 38

Type	Size	Length		Load capacity per pair C_{Orad} [N]	Y	m	n	E	C	Number of holes
		L [mm]	H [mm]							
H1T	100	700	1050	5500	100	200	-	-	100	8
		750	1125	5500					150	
		800	1200	5300					200	
		850	1275	5100					250	
		900	1350	4700					300	
		950	1425	4500					350	
		1000	1500	4300					400	
		1100	1650	4000					150	
	1200	1800	3700	200						
	1300	1950	3400	250						
	1400	2100	3100	300						
	1500	2250	2900	350						
	1600	2400	2600	400						
	1700	2550	2300	450						
	1800	2700	2000	500						
	1900	2850	1700	550						
	2000	3000	1400	600						

The load capacity for aluminum is 40% and for stainless steel 60% of the stated values, if available in this material variant (see Technical features overview).

Tab. 14

Other sizes and versions are available on request

Type	Size	Length	Load capacity
		L [mm]	per pair C_{0rad} [N]
H1T	150	700	7000
		⋮	⋮
		2000	2300

Tab. 15

The load capacity for aluminum is 40 % and for stainless steel 60 % of the stated values, if available in this material variant (see Technical features overview).

> H1T

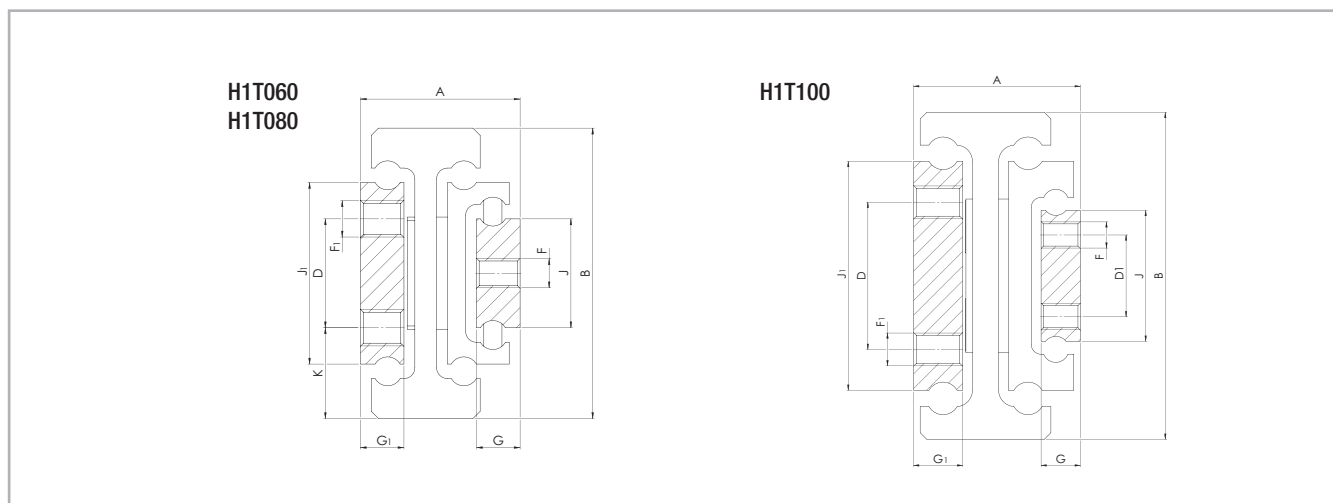

All dimensions are indicated in mm

Fig. 39

Type	Size	A	B	J	J1	G	G1	K	D	D1	F	F1	Weight per single guide [kg/m]
H1T	60	40.5	60	25	40	12	10	19	22	-	M8	M6	12.90
	80	44	80	30	50		12	25	30			M10	18.60
	100	51	100	40	70		15	27.5	45			25	M10

Tab. 16

> H2H080

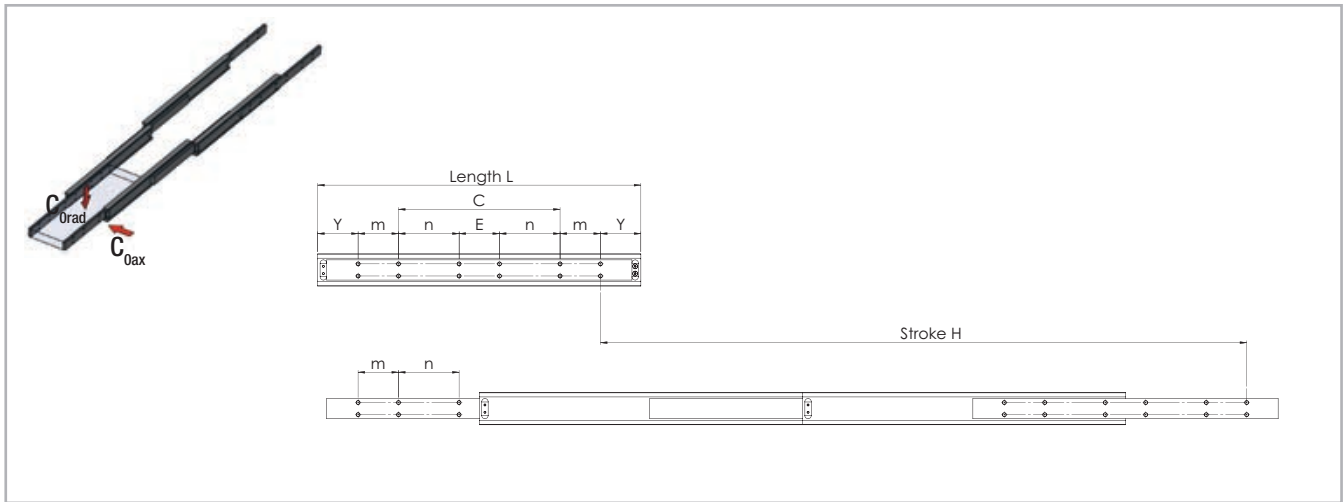

All dimensions are indicated in mm

Fig. 40

Type	Size	Length		Load capacity per pair C_{grad} [N]	Y	m	n	E	C	Number of holes
		L [mm]	H [mm]							
H2H	80	500	1000	on request	100	100	-	-	100	8
		550	1100						150	
		600	1200						200	
		650	1300						250	
		700	1400						300	
		750	1500						350	
		800	1600				150	100	-	12
		850	1700				175			
		900	1800				200			
		950	1900				225			
		1000	2000				250			
		1100	2200				300			
		1200	2400				350			
		1300	2600				400			
		1400	2800				450			
		1500	3000				500			

The load capacity for aluminum is 40% and for stainless steel 60% of the stated values, if available in this material variant (see Technical features overview).

Tab. 17

> H2H080

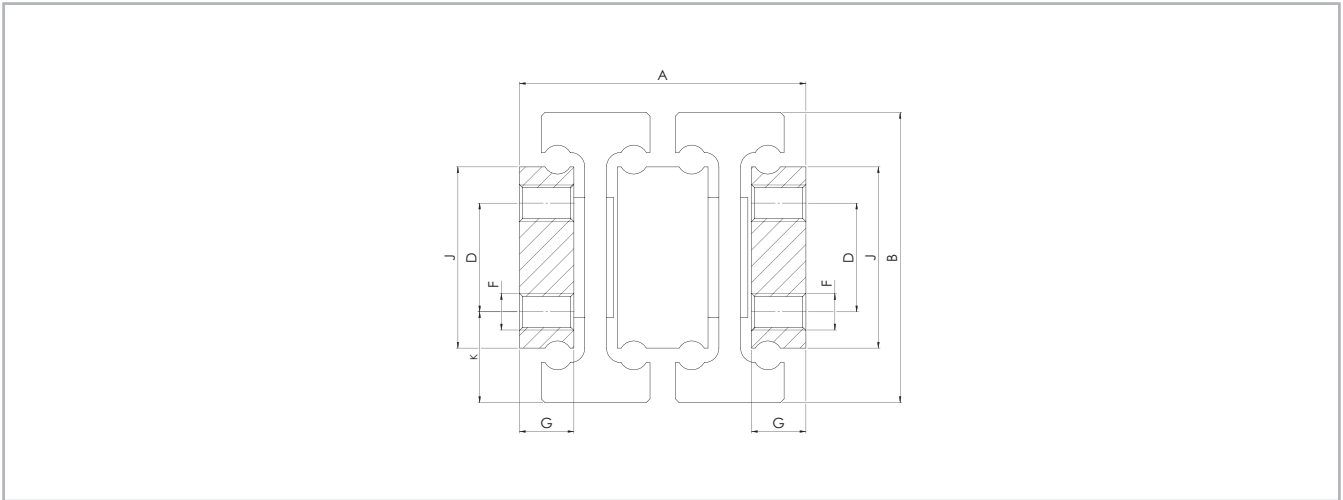

All dimensions are indicated in mm

Fig. 41

Type	Size	A	B	J	G	K	D	F	Weight per single guide [kg/m]
H2H	80	79+ -1	80	50	15	25	30	M10	34.80

Tab. 18

> LTH30 RF

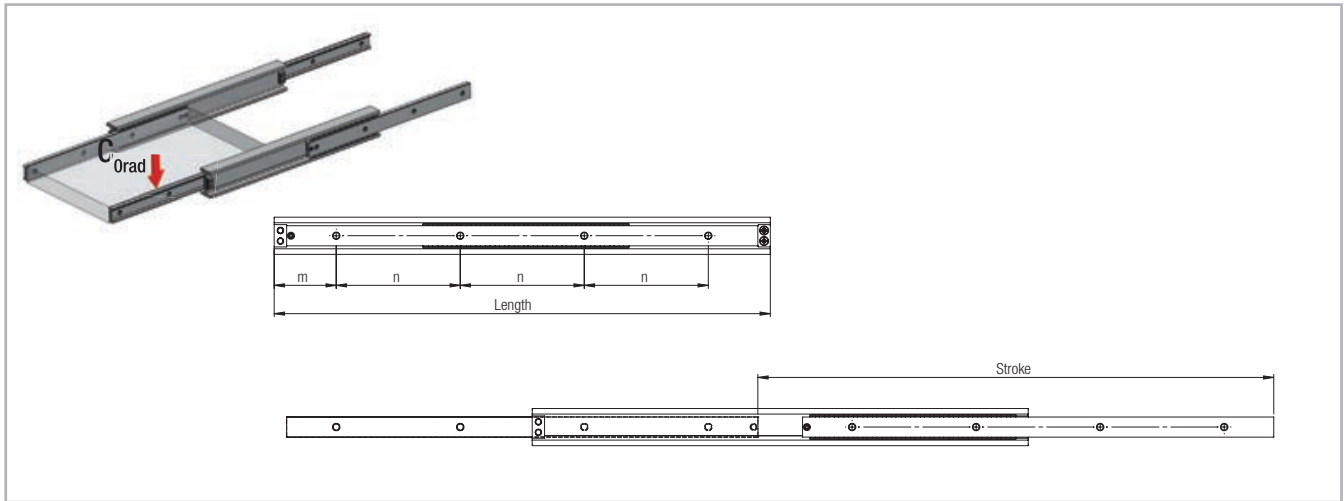

Fig. 42

Type	Size	Length		Load capacity per pair		m [mm]	n [mm]	Number of holes
		L [mm]	H [mm]	C_{Orad} [N]	C_{Oax} [N]			
LTH	30	250	285	404	on request	25	100	3
		300	323	1008		50		
		350	377	1042		25		4
		400	416	1136		50		
		450	485	1164		25		5
		500	523	1470		50		
		550	577	1464		25		6
		600	615	1402		50		
		650	685	1230		25		7
		700	723	1186		50		
		750	777	1100		25		8
		800	815	1066		50		
		850	884	962		25		9
		900	923	936		50		
		950	977	882		25		10
		1000	1015	858		50		
1050	1084	792	25	11				
1100	1123	772	50					
1150	1176	736	25	12				
1200	1215	720	50					

Tab. 19

> LTH30 KF

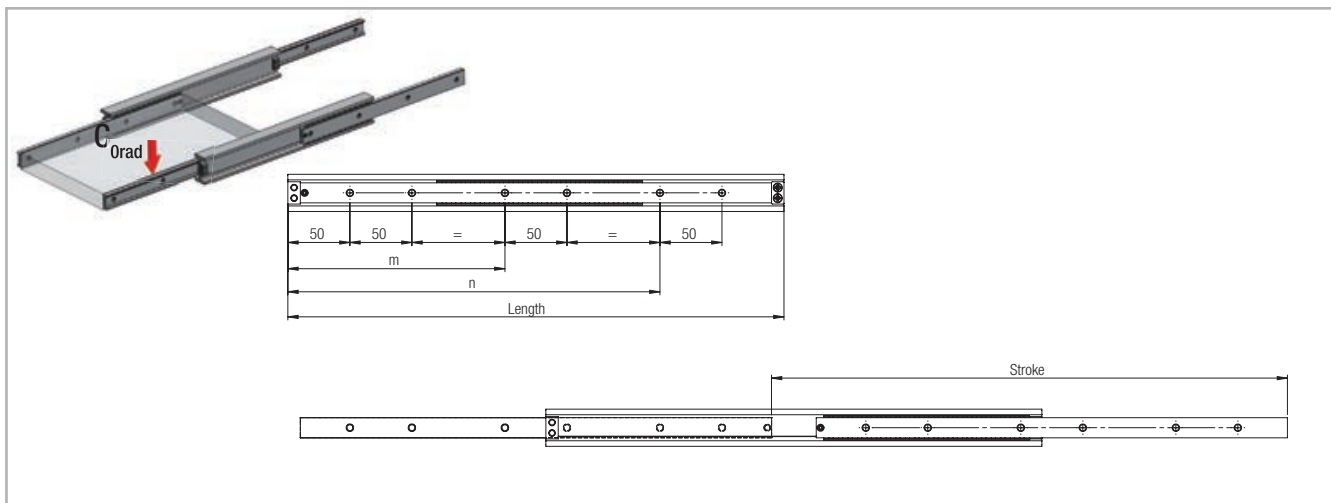

Fig. 43

Type	Size	Length L [mm]	Stroke H [mm]	Load capacity per pair		m [mm]	n [mm]	Number of holes
				C_{Orad} [N]	C_{Oax} [N]			
LTH	30	250	285	404	on request	-	150	4
		300	323	1008			200	
		350	377	1042			250	
		400	416	1136		175	300	6
		450	485	1164		200	350	
		500	523	1470		225	400	
		550	577	1464		250	450	
		600	615	1402		275	500	
		650	685	1230		300	550	
		700	723	1186		325	600	
		750	777	1100		350	650	
		800	815	1066		375	700	
		850	884	962		400	750	
		900	923	936		425	800	
		950	977	882		450	850	
		1000	1015	858		475	900	
		1050	1084	792		500	950	
		1100	1123	772		525	1000	
1150	1176	736	550	1050				
1200	1215	720	575	1100				

Tab. 20

H
R

> LTH30 S

... S version with reinforced and dampened end stops made of stainless steel

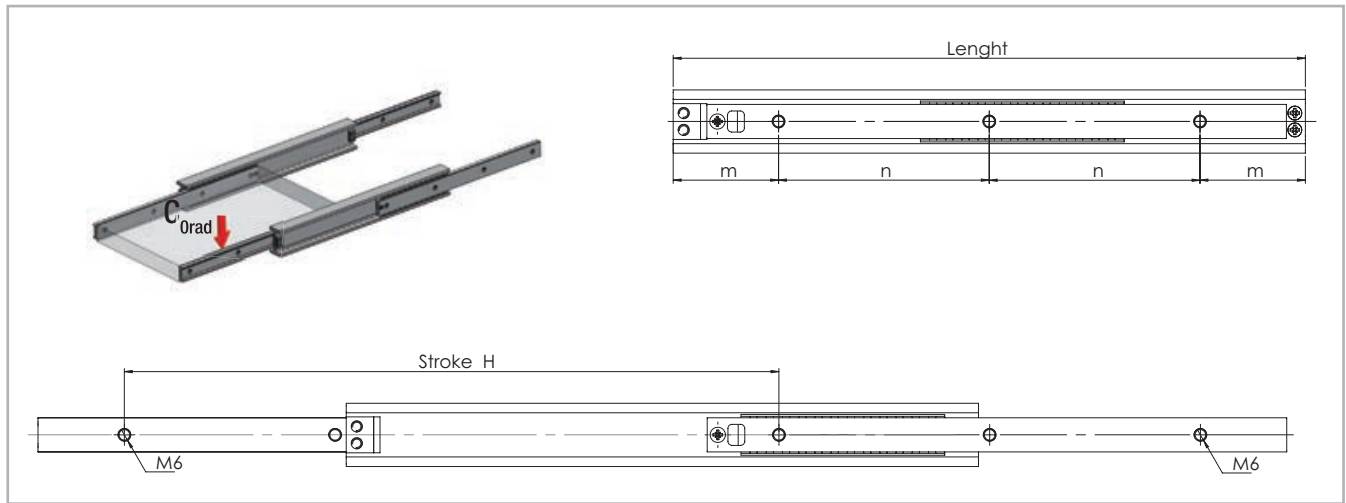

Fig. 44

Type	Size	Length L [mm]	Stroke H [mm]	Load capacity per pair		m [mm]	n [mm]	Number of holes
				C_{0rad} [N]	C_{0ax} [N]			
LTH...S	30	300	310	816	on request	50	100	3
		350	364	880		75		
		400	402	994		50		
		450	472	1032		75		4
		500	510	1330		50		
		550	564	1498		75		5
		600	618	1392		50		
		650	671	1276		75		6
		700	725	1178		50		
		750	764	1138		75		7
		800	817	1060		50		
		850	871	992		75		8
		900	925	932		50		
		950	979	878		75		9
		1000	1017	856		50		
		1050	1071	810		75		10
1100	1109	790	50					
1150	1179	732	75	11				
1200	1217	718	50					

Tab. 21

> LTH45 RF

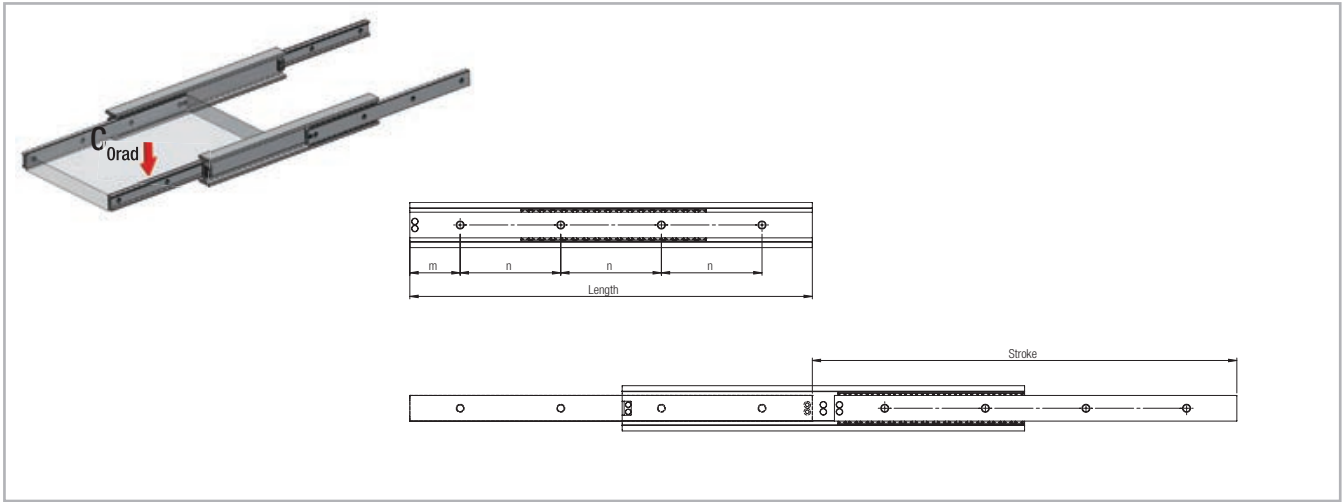

Fig. 45

Type	Size	Length L [mm]	Stroke H [mm]	Load capacity per pair		m [mm]	n [mm]	Number of holes
				C_{Orad} [N]	C_{Oax} [N]			
LTH	45	250	276	2610	on request	25	100	3
		300	310	2824		50		
		350	388	2820		25		4
		400	422	2842		50		
		450	478	2864		25		5
		500	512	2900		50		
		550	590	2764		25		6
		600	624	3032		50		
		650	680	3252		25		7
		700	714	3346		50		
		750	770	3084		25		8
		800	826	2860		50		
		850	882	2666		25		9
		900	916	2614		50		
		950	972	2450		25		10
		1000	1028	2306		50		
		1050	1084	2178		25		11
		1100	1118	2144		50		
		1150	1174	2034		25		12
		1200	1230	1934		50		
1250	1286	1842	25	13				
1300	1320	1818	50					
1350	1376	1738	25	14				
1400	1410	1716	50					
1450	1488	1596	25	15				
1500	1522	1578	50					

Tab. 22

> LTH45 KF

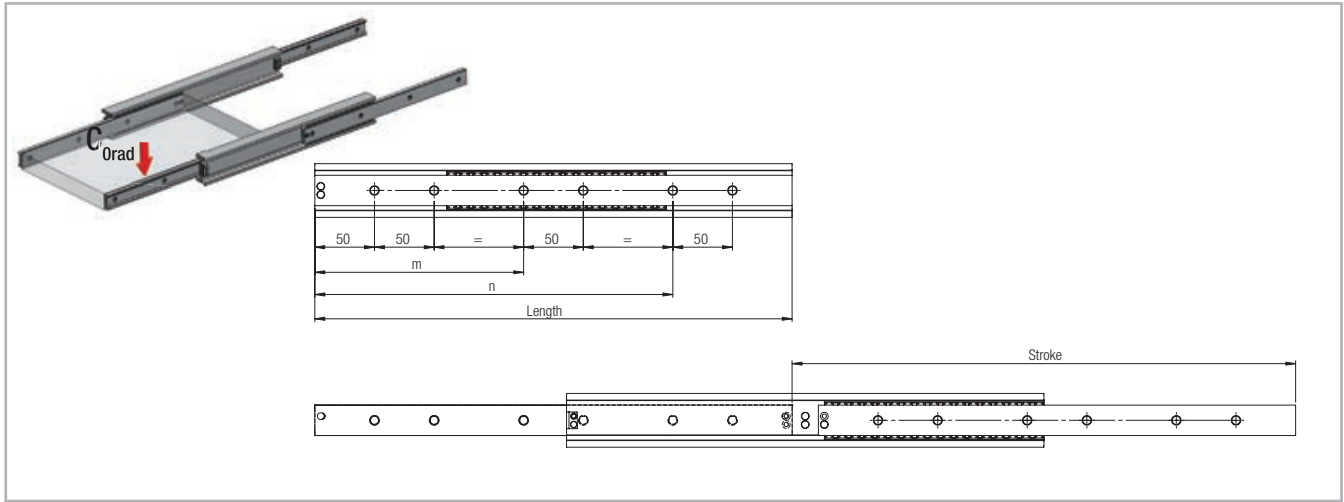

Fig. 46

Type	Size	Length L [mm]	Stroke H [mm]	Load capacity per pair		m [mm]	n [mm]	Number of holes
				C_{Orad} [N]	C_{Oax} [N]			
LTH	45	250	276	2610	on request	-	150	4
		300	310	2824			200	
		350	388	2820			250	
		400	422	2842			175	
		450	478	2864		200	350	
		500	512	2900		225	400	
		550	590	2764		250	450	
		600	624	3032		275	500	
		650	680	3252		300	550	
		700	714	3346		325	600	
		750	770	3084		350	650	
		800	826	2860		375	700	
		850	882	2666		400	750	
		900	916	2614		425	800	
		950	972	2450		450	850	
		1000	1028	2306		475	900	
		1050	1084	2178		500	950	
		1100	1118	2144		525	1000	
		1150	1174	2034		550	1050	
		1200	1230	1934		575	1100	
1250	1286	1842	600	1150				
1300	1320	1818	625	1200				
1350	1376	1738	650	1250				
1400	1410	1716	675	1300				
1450	1488	1596	700	1350				
1500	1522	1578	725	1400				

> LTH45 S

... S version with reinforced and dampened end stops made of stainless steel

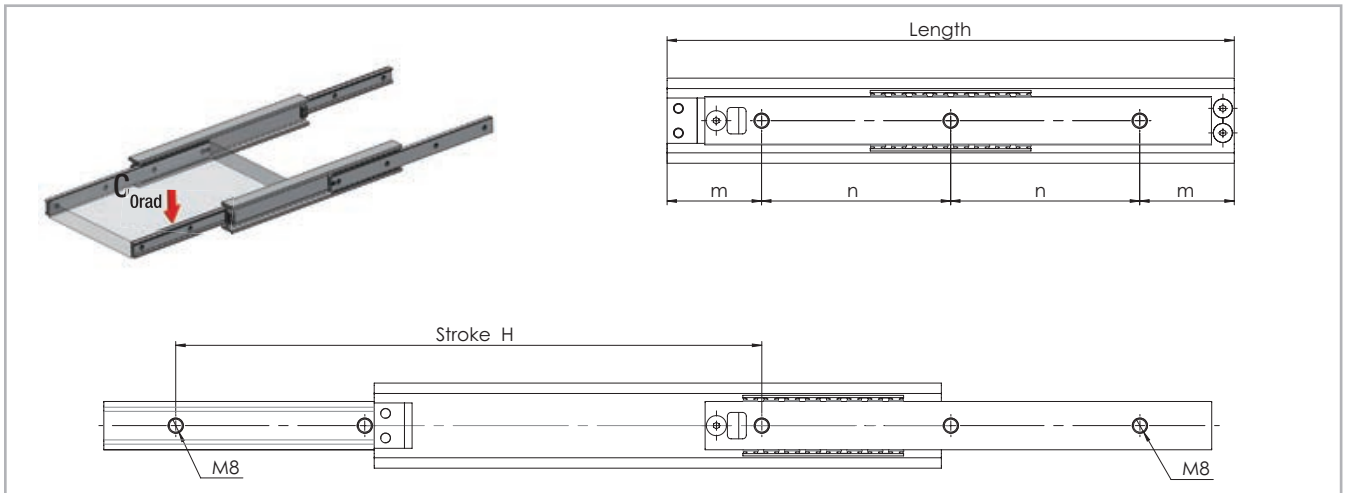
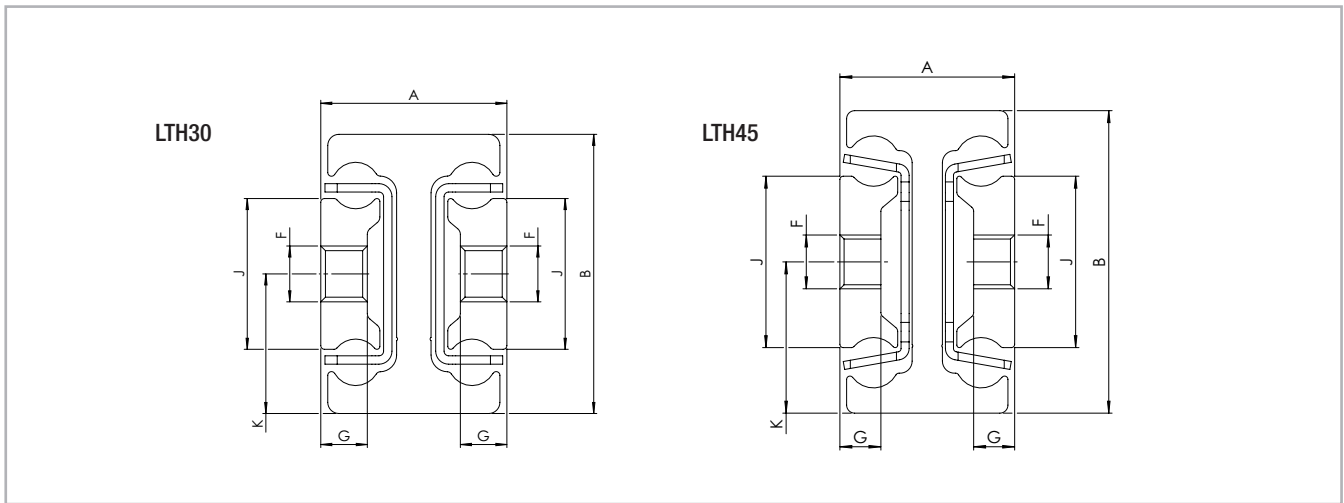

Fig. 47

Type	Size	Length L [mm]	Stroke H [mm]	Load capacity per pair		m [mm]	n [mm]	Number of holes
				C_{Orad} [N]	C_{Oax} [N]			
LTH...S	45	300	310	1316	on request	50	100	3
		350	366	1832		75		4
		400	422	1666		50		5
		450	456	2154		75		6
		500	512	1972		50		7
		550	568	2200		75		8
		600	624	2204		50		9
		650	680	2426		75		10
		700	714	2942		50		11
		750	770	3084		75		12
		800	826	2860		50		13
		850	882	2666		75		14
		900	916	2614		50		15
		950	972	2450		75		
		1000	1028	2306		50		
		1050	1084	2178		75		
		1100	1118	2144		50		
		1150	1174	2034		75		
		1200	1230	1934		50		
		1250	1286	1842		75		
1300	1320	1818	50					
1350	1376	1738	75					
1400	1410	1716	50					
1450	1488	1596	75					
1500	1522	1578	50					

Tab. 24

> LTH



All dimensions are indicated in mm

Fig. 48

Type	Size	A	B	J	G	K	F	Weight per single guide [kg/m]
LTH	30	20	30	16.2	5.0	15.0	M6	3.5
	45	26	45	25.5	6.1	22.5	M8	6.0

Tab. 25

> LTH Special strokes

Special strokes are defined as deviations from standard stroke.

They are each available as multiples of the values in tab. 26.

These values are dependent on the spacing of the ballcage.

Type	Size	Stroke modification [mm]
LTH	30	15,4
	45	22

Tab. 26

Each stroke modification influences the load capacities stated in the catalogue. For more information please contact Rollon technical support.

> HGT060, HGT080, HGT100, HGT120, HGT150, HGT200, HGT240

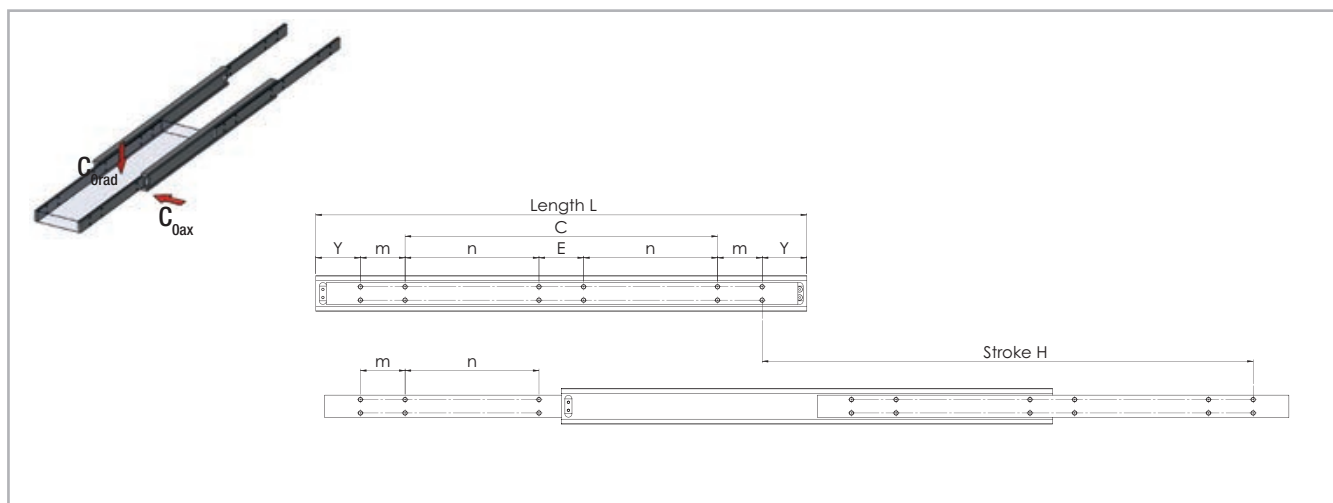

All dimensions are indicated in mm

Fig. 49

Type	Size	Length L [mm]	Stroke H [mm]	Load capacity per pair		Y	m	n	E	C	Number of holes
				C _{Orad} [N]	C _{Oax} [N]						
HGT	60	400	400	5250	on request	50	50	-	-	200	8
		450	450	5350				-	-	250	
		500	500	5400				-	-	300	
		550	550	5500				150	50	-	12
		600	600	5400				175			
		650	650	5350				200			
		700	700	5250				225			
		750	750	5100				250			
		800	800	4900				275			
		850	850	4700				300			
		900	900	4500				325			
		950	950	4300				350			
		1000	1000	4050				375			
		1100	1100	3700				425			
		1200	1200	3300				475			
		1300	1300	2900				525			
1400	1400	2500	575								
1500	1500	2100	625								

The load capacity for aluminum is 40% and for stainless steel 60% of the stated values, if available in this material variant (see Technical features overview).

Tab. 27

4 Load capacities and dimensions

Type	Size	Length	Stroke	Load capacity per pair		Y	m	n	E	C	Number of holes	
				C _{Grad} [N]	C _{Oax} [N]							
HGT	80	500	500	9000	on request	100	100			100	8	
		550	550	9250						150		
		600	600	9350						200		
		650	650	9200						250		
		700	700	9050						300		
		750	750	8800						350		
		800	800	8600						400		
		850	850	8350						450		
		900	900	8100						500		
		950	950	7850						550		
		1000	1000	7550				600				
		1100	1100	7150				300	100	-		12
		1200	1200	6700				350				
		1300	1300	6200				400				
		1400	1400	5700				450				
		1500	1500	5200				500				
		1600	1600	4600				550				
		1700	1700	4100				600				
		1800	1800	3600				650				
		1900	1900	3000				700				
2000	2000	2500	750									

The load capacity for aluminum is 40% and for stainless steel 60% of the stated values, if available in this material variant (see Technical features overview).

Tab. 28

Type	Size	Length		Stroke		Load capacity per pair		Y	m	n	E	C	Number of holes		
		L [mm]	H [mm]	C _{Orad} [N]	C _{Oax} [N]										
HGT	100	700	700	11000	on request	100	200	-	-	-	100	8			
		750	750	10750							150				
		800	800	10500							200				
		850	850	10250							250				
		900	900	10000							300				
		950	950	9750							350				
		1000	1000	9500							400				
		1100	1100	9000							150		200	-	12
		1200	1200	8500							200				
		1300	1300	7900							250				
	1400	1400	7300	300											
	1500	1500	6700	350											
	1600	1600	6100	400											
	1700	1700	5450	450											
	1800	1800	4800	500											
	1900	1900	4100	550											
	2000	2000	3400	600											

The load capacity for aluminum is 40% and for stainless steel 60% of the stated values, if available in this material variant (see Technical features overview).

Tab. 29

Other sizes and versions are available on request

Type	Size	Length		Load capacity per pair	
		L [mm]	C _{Orad} [N]	C _{Oax} [N]	
HGT	120	700	11500	on request	
		⋮	⋮		
		2000	4700		
	150	700	13900		
		⋮	⋮		
		2000	7000		
	200	700	15000		
		⋮	⋮		
		2300	6700		
	240	700	17500		
		⋮	⋮		
		2000	12500		

The load capacity for aluminum is 40% and for stainless steel 60% of the stated values, if available in this material variant (see Technical features overview).

Tab. 30

> HGT

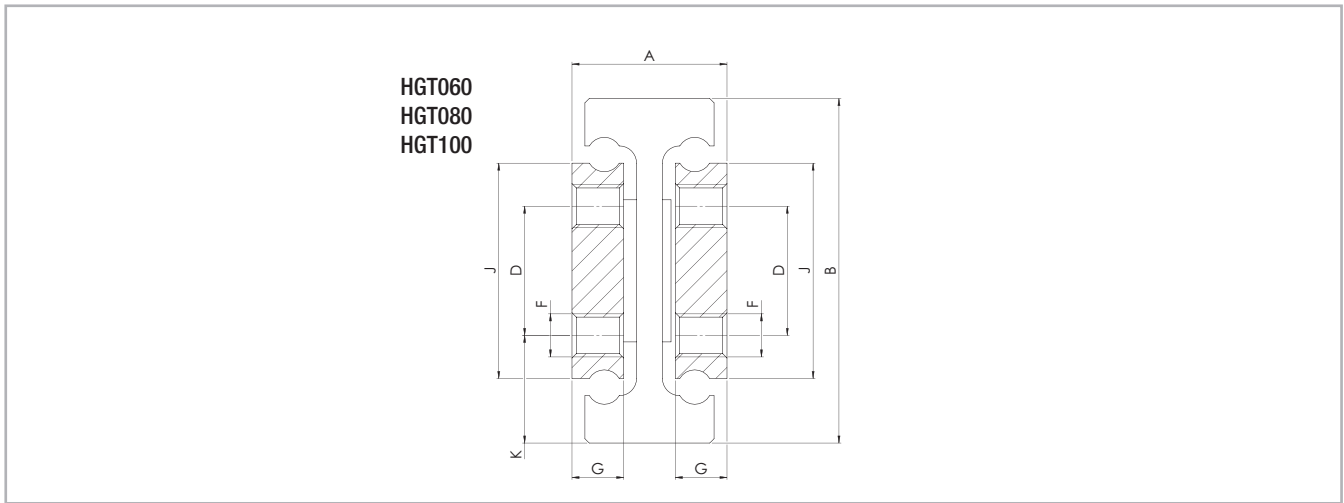

All dimensions are indicated in mm

Fig. 50

Type	Size	A	B	J	G	K	D	F	Weight per single guide [kg/m]
HGT	60	32	60	40	10	19	22	M6	11.70
	80	36	80	50	12	25	30	M10	17.50
	100	44	100	70	15	27.5	45		27.60

Tab. 31

> LTF44

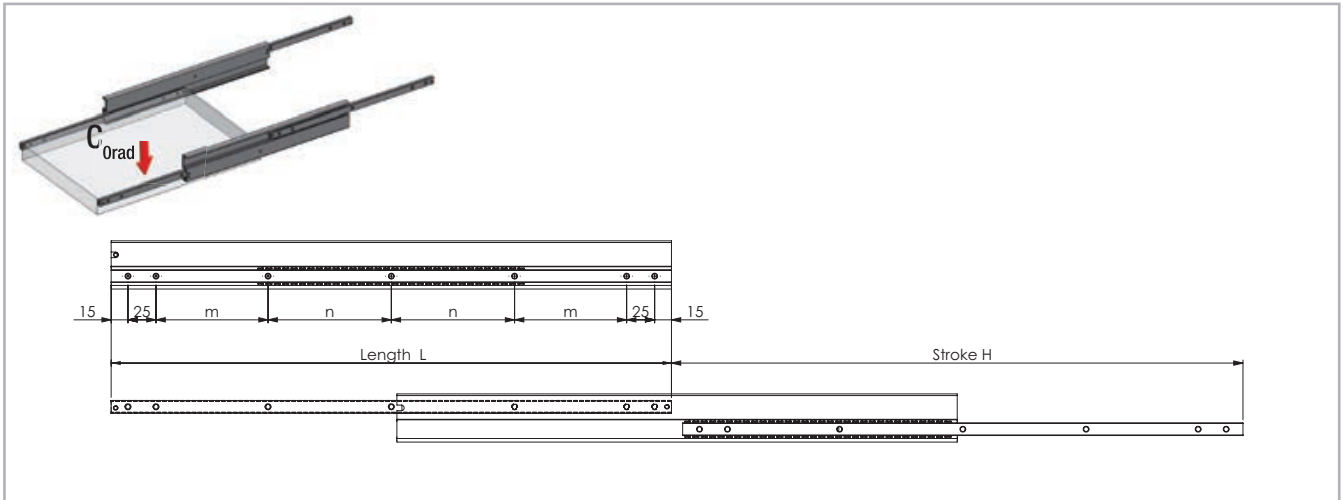

All dimensions are indicated in mm

Fig. 51

Type	Size	Length	Stroke	Load capacity per pair C_{Orad} [N]	Fixed and moving rails		Number of holes
		L [mm]	H [mm]		m [mm]	n [mm]	
LTF	44	200	210	228	60	-	5
		225	235	260	72.5		
		250	260	288	85		
		275	285	324	97.5		
		300	310	360	110		
		325	335	392	122.5		
		350	360	420	135		
		375	385	452	147.5		
		400	410	492	160		
		425	435	524	172.5		
	450	460	552	185	100	7	
	500	510	624	110			
	550	560	684	135			
	600	610	768	160			
	650	660	816	185			
	700	710	888	160			
	750	760	948	185			
	800	810	1020	210			
	850	860	1080	235			
	900	910	1152	260			
950	960	1224	285	150	310		
1000	1010	1296	310				

Tab. 32

> LTF44

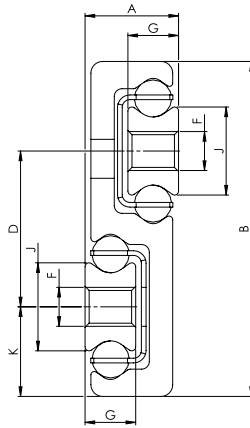

All dimensions are indicated in mm

Fig. 52

Type	Size	A	B	J	G	K	D	F	Weight per single guide [kg/m]
LTF44	44	12	43	11.3	6.5	11.5	20	M5	2.7

Tab. 33

> HGS060

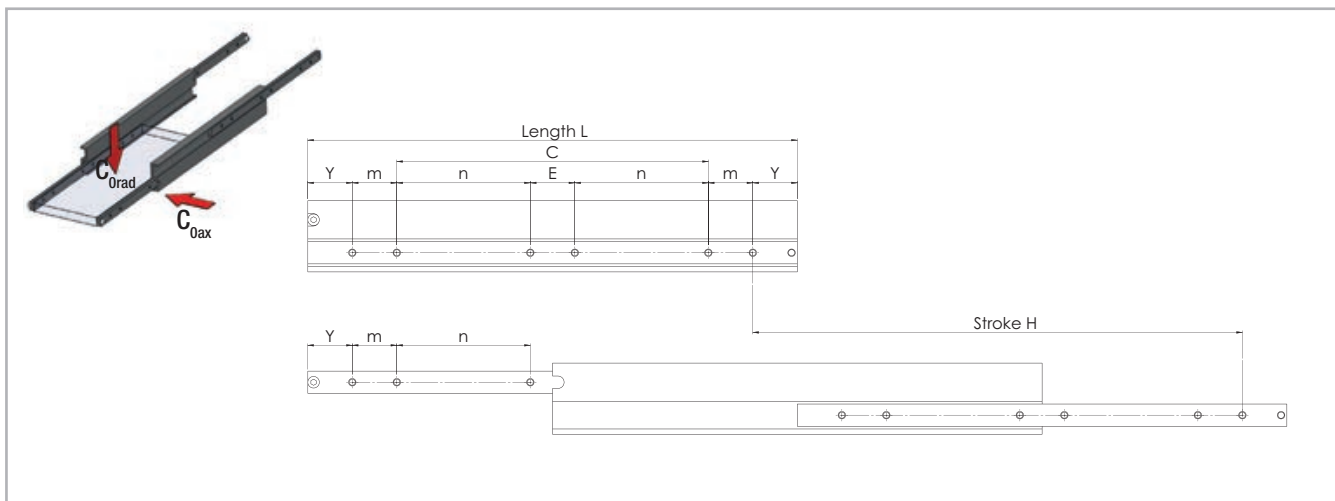

All dimensions are indicated in mm

Fig. 53

Type	Size	Length	Stroke	Load capacity per pair C_{Orad} [N]	Y	m	n	E	C	Number of holes
		L [mm]	H [mm]							
HGS	60	250	250	1000	50	50	-	-	50	4
		300	300	1250					100	
		350	350	1350					150	
		400	400	1400					200	
		450	450	1400					250	
		500	500	1400					300	
		550	550	1350			150	50	-	
		600	600	1300			175			
		650	650	1250			200			
		700	700	1200			225			
		750	750	1150			250			
		800	800	1050			275			
		850	850	950			300			
		900	900	850			325			
		950	950	750			350			
		1000	1000	650			375			

The load capacity for aluminum is 40% and for stainless steel 60% of the stated values, if available in this material variant (see Technical features overview).

Tab. 34

> HGS

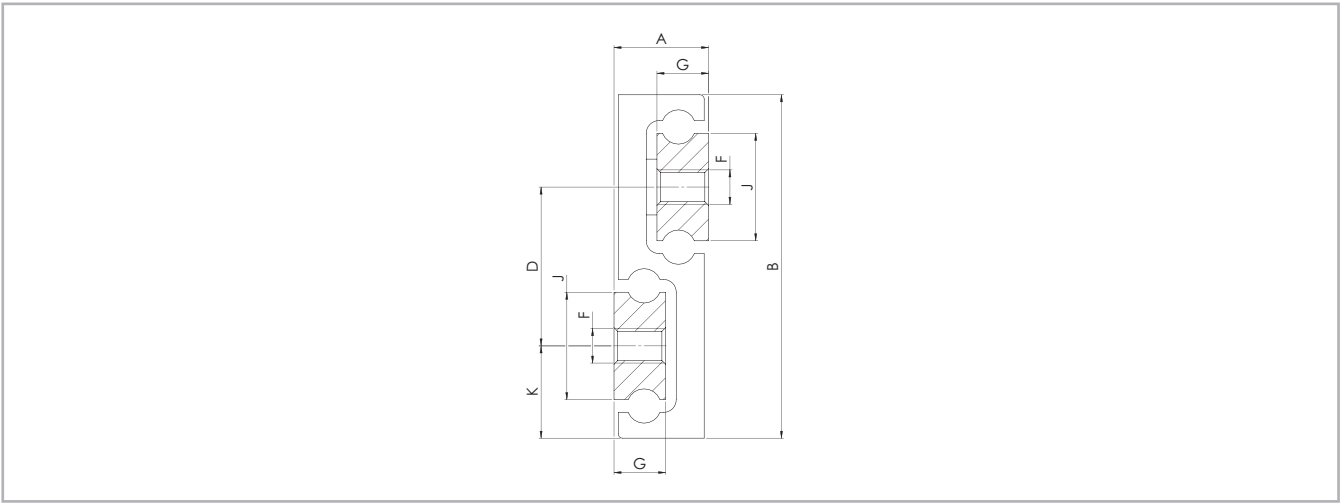

All dimensions are indicated in mm

Fig. 54

Type	Size	A	B	J	G	K	D	F	Weight per single guide [kg/m]
HGS	60	17	60	16	10	16	28	M6	6.00

Tab. 35

Accessories

Available options (depending on telescope version)

> Locking

Locking mechanisms make it possible to lock the Hegra rails in the end position. This prevents inadvertent extension or retraction of the rail in any case. Locking mechanisms can be implemented as locking bolts or bars. This ensures personal safety and protection of materials, especially in moving installations, as in vehicles. For models HGT with locking please observe right or left side use.



Fig. 55



Fig. 56

> Driving disc

In the full extension rails with dual stroke the intermediate element does not follow a particular order. The exact position of the element is therefore defined only in fully extended condition. The optional driving disc defines the movement of the intermediate element. This prevents unwanted protrusion of the element. An example for use of the driving disc is in warehouse rails, which are extended in both directions.

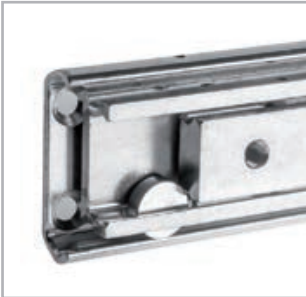

Fig. 57



Fig. 58

> Damping

Hegra telescoping rails can be equipped with damped end stops in closed position. Plastic or elastomer damping elements provide for quieter operation, a softer end stop when pushing in the rail and higher resistance at the end of the stroke.

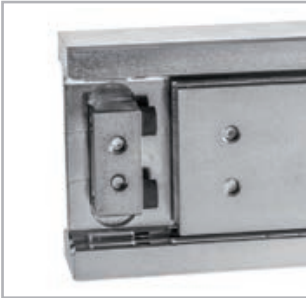

Fig. 59



Fig. 60

> Snap

Hegra Rail telescopic guides can be partial with a snap through a ball thrust piece. Thus, an unintended process of the telescope system is avoided.

Note: Not all accessories (interlocks, damping, Drive disk, snap) can be combined with each other and available. (see Technical features overview) Please contact our technical service.

Technical information



> Selecting a suitable telescoping rail

To find a telescoping rail that meets your requirements, the following factors must be considered.

- Desired load capacity
- Available sizes (height, width and rail length)
- Required extension type (partial, full extension, etc.)
- Length of travel
- Desired material and surface

> Mounting tolerances

Installation

length (mm)	$\geq 150 < 420$	$\geq 420 < 1050$	$\geq 1050 < 2840$
Tolerance (mm)	± 0.5	± 0.8	± 1.2

At the installation, width tolerances of ± 0.5 mm for compensating are to be considered. For all other dimensions, the tolerances according to DIN ISO 2768-1 (m) apply.

> Life cycle

The life cycle describes the time span from installation to failure of the telescoping rail, due to wear.

The life cycle is affected by the following factors.

- Load
- Assembly precision
- Parallelism when installed in pairs
- Rigidity of the connection construction
- Jolts and vibrations
- Operating temperature
- Lubrication (in accordance with maintenance intervals)

> Load capacity

The specified maximum load capacity always refers to one pair of vertically installed telescoping rails. To achieve this capacity, the following requirements must be fulfilled.

- An absolutely rigid connection construction
- Even distribution of the load over the entire length of the moving rail element
- Mounting of the telescoping rails on a flat and rigid surface using all provided mounting holes
- Please be sure to use the correct screw length to prevent damage to the ball cage: shank length of screw $<$ thickness of the moving element
- Vertical installation of telescoping rails

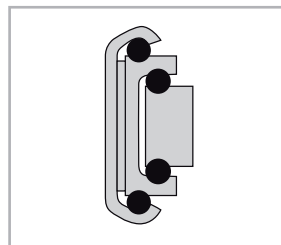

Vertical installation

Fig. 61

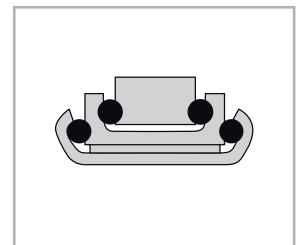

Level installation

Fig. 62

If optimal implementation of all of these requirements is not possible, we will be glad to assist you in calculating the actual load capacity.

In case of a level installation of the telescoping rails (axial load direction), only a reduced value of the radial load capacity is possible.

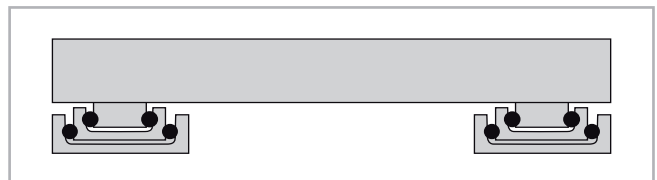

Fig. 63

> Deflection

If the telescopic guides of the HGT series are assembled in pairs and the requirements under "Load capacity" are taken into account, the maximum deflection of steel rails under full load is 1 % of the extended length (stroke). Example: 500 mm length of travel -> max. 5 mm deflection under full load.

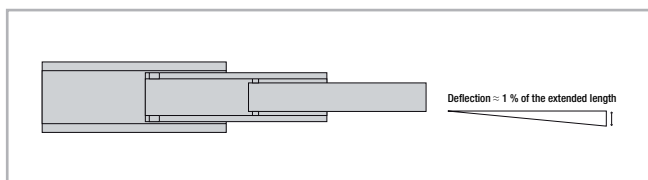

Fig. 64

Note: All other deflection of the Hegra Rail product family on request

> Operating temperature

The telescopic rails can be used at ambient temperatures from -20 °C to +170 °C (-4 °F to +338 °F). At lower temperatures down to -30 °C (-22 °F) or higher temperatures up to +250 °C (+482 °F), please contact our application engineers. These ranges always require the use of a special lubricant.

The operating temperature is -20 °C to + 50 °C (-4 °F to + 122 °F) when damping is used.

> Corrosion protection

As standard features, all series are zinc electroplated, thick-film passivated and Reach/RoHs compliant. For higher corrosion protection we offer zinc nickel plating with stainless steel balls. Overview of available coatings:

Coating type thickness 12-15µm	Salt-spray test DIN EN ISO 9227	Reach/ RoHS
Thick-film passivated	ca. 400 hours	yes
Zinc nickel	more than 700 h	yes

Tab. 36

> Clearance and preload

Hegra Rail guides are mounted as standard with no play. For more information, please contact Rollon technical support.

Preload classes		
Increased clearance	No clearance	Increased preload
G ₁	Standard	K ₁

Tab. 37

* for higher preload, contact Rollon technical support.

> Ball cage displacement

The stroke movement of a telescoping rail is achieved by the ball cages, among other elements. You should ensure that the telescoping rail is always fully extended and retracted, since otherwise the ball cages can become displaced. Ball cage displacement occurs as a result of slippage and means that you can achieve the required extension length and the desired closed condition of the telescoping rail only with increased application of force.

Automated systems must have sufficient reserve driving force or an additional maximum stroke must be planned for in order to prevent displacement.

On request we also implement custom design solutions. Feel free to contact us.

> Moving force

The moving force is subject to production-related tolerances and is also defined by the load and the deflection of a telescoping rail. Taking into account the load and deflection of a telescoping rail, the closing force is higher than the opening force, since deflection occurs under load and closing takes place by pushing against a slanted plane.

> Lubrication

Alternative lubricants, for example for the food industry, or alternate temperature ranges are available on request. Our aluminium or stainless steel telescoping rails are generally delivered without grease.

> Maintenance intervals

A visual inspection should be conducted occasionally; foreign particles should be removed and “dry” guide rails should be lightly lubricated with roller bearing grease. This prevents friction, protects the components and prolongs the life of the system. The lubrication intervals are variable and should be determined based on the respective operating conditions such as load, ambient conditions, travel speed, temperature, pollution, etc.

> Mounting instructions

- Please use all mounting holes, in addition to screws of the correct length.
- A stable base is necessary for mounting the telescoping rails.
- In the connection construction, be aware that we have switched to counterbores according to DIN 74 Form F and due to the material thickness of our profiles, the head of the countersunk screw protrudes somewhat from the profile, so that the mating piece must have a corresponding counterbore.

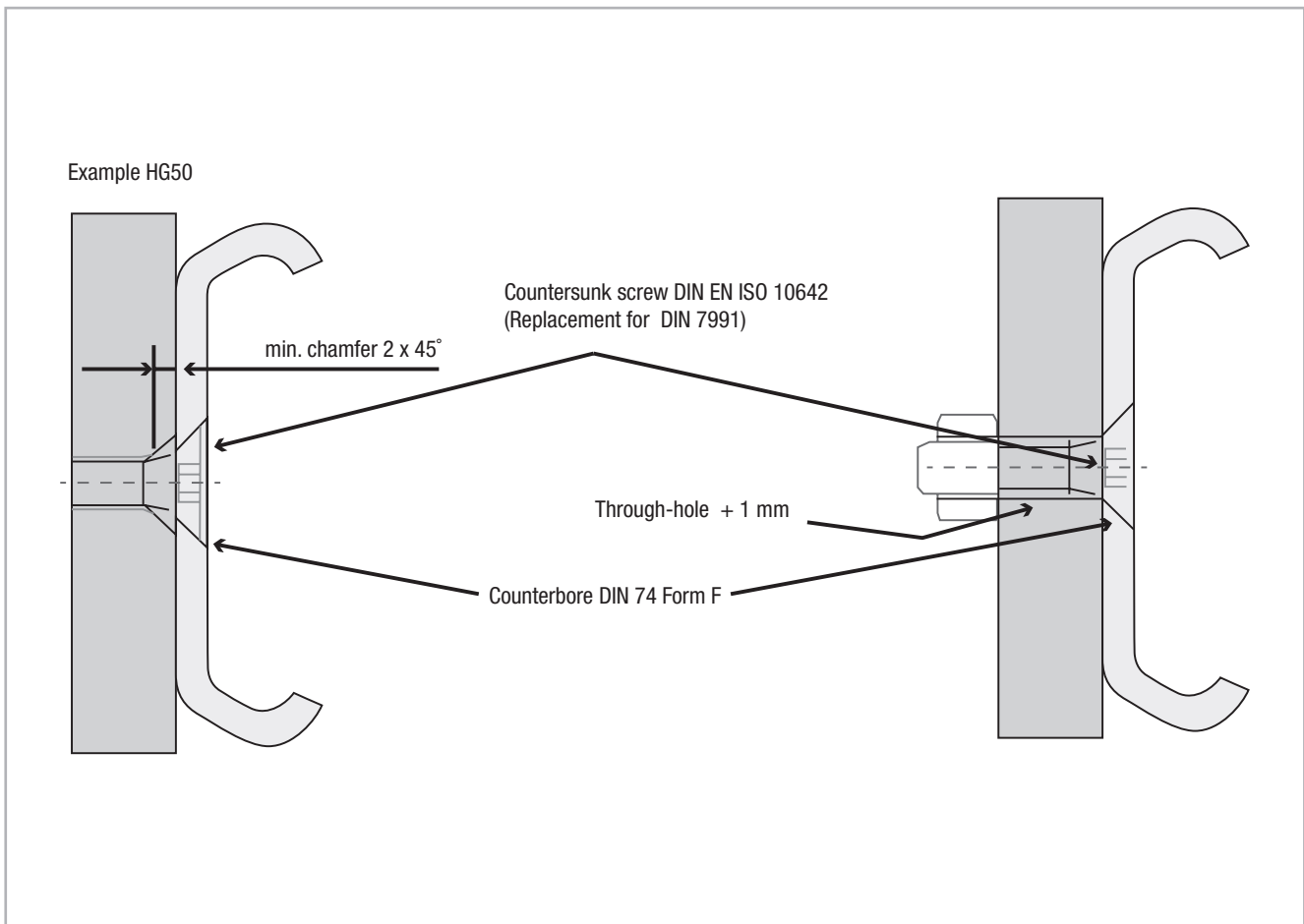

Fig. 65

Ordering key

> Hegra Rail

HGTX080	0500	0600	EG	VO	DG	B	Z	R	
									right or left version
									alternate coating
									stroke in both directions
									damping
									locking
									snap
									alternate stroke
									closed length
type with material and size									

Note on ordering: The size is always indicated as 3 digits, the length of the rail and the stroke are always 4 digits with the 0 prefixes.

Not all fields must be filled out. If they are not used, they remain empty.

Ordering example: HGTX080-0500-0600-EG-VO-DG-B-Z-R

Type	
HTT	partial extension machined/drawn profile
HVC	full extension single c-profile
H1C	over extension 150 % single c-profile
H1T	over extension 150 % machined/drawn profile
H2H	over extension 200 % machined/drawn profile
LTH	heavy duty slide
HGT	heavy duty slide
LTF	s-profile
HGS	s-profile

Material	
	steel
A	aluminum
X*	stainless steel

* Different stainless steels, such as the “electropolishing” option, are available, please contact our technical service.

*To process your order for stainless steel telescopic systems we need the material number you prefer. Please consider: Our standard material for rails and sliders in V2A is 1.4301 (AISI304), in V4A it is 1.4571 (AISI316Ti) and that the material of our stainless balls is 1.4034 (AISI420)

Accessory	
	no accessory
EO	snap on opened position
EG	snap on closed position
EB	snap on closed an opened position
VO	locking opened position
VG	locking closed position
VB	locking on closed an opened position
DG	damping closed position
B	stroke on closed an opened position
BM	stroke on closed an opened position with synchronization

Coating	
	thick-film passivation
Z	zinc nickel
N	nickel
E	anodizing colorless

Layout	
L	left version
R	right version

Special/Configuration	
S01	special (according to drawing)
C01	configuration (special stroke, stainless steel balls, special grease)



Follow us:



● Rollon Branches & Rep. Offices
● Distributors

EUROPE

ROLLON S.p.A. - ITALY (Headquarters) ▼

Via Trieste 26
I-20871 Vimercate (MB)
Phone: (+39) 039 62 59 1
www.rollon.it - infocom@rollon.it

ROLLON GmbH - GERMANY ▼

Bonner Strasse 317-319
D-40589 Düsseldorf
Phone: (+49) 211 95 747 0
www.rollon.de - info@rollon.de

ROLLON S.A.R.L. - FRANCE ▼

Les Jardins d'Eole, 2 allée des Séquoias
F-69760 Limonest
Phone: (+33) (0) 4 74 71 93 30
www.rollon.fr - infocom@rollon.fr

ROLLON B.V. - NETHERLANDS ▼

Ringbaan Zuid 8
6905 DB Zevenaar
Phone: (+31) 316 581 999
www.rollon.nl - info@rollon.nl

ROLLON S.p.A. - RUSSIA (Rep. Office) ▼

117105, Moscow, Varshavskoye
shosse 17, building 1
Phone: +7 (495) 508-10-70
www.rollon.ru - info@rollon.ru

ROLLON Ltd - UK (Rep. Office) ▼

The Works 6 West Street Olney
Buckinghamshire, United Kingdom, MK46 5 HR
Phone: +44 (0) 1234964024
www.rollon.uk.com - info@rollon.uk.com

AMERICA

ROLLON Corporation - USA ▼

101 Bilby Road. Suite B
Hackettstown, NJ 07840
Phone: (+1) 973 300 5492
www.rolloncorp.com - info@rolloncorp.com

ROLLON - SOUTH AMERICA (Rep. Office) ▼

R. Joaquim Floriano, 397, 2o. andar
Itaim Bibi - 04534-011, São Paulo, BRASIL
Phone: +55 (11) 3198 3645
www.rollonbrasil.com.br - info@rollonbrasil.com

ASIA

ROLLON Ltd - CHINA ▼

No. 1155 Pang Jin Road,
China, Suzhou, 215200
Phone: +86 0512 6392 1625
www.rollon.cn.com - info@rollon.cn.com

ROLLON India Pvt. Ltd. - INDIA ▼

1st floor, Regus Gem Business Centre, 26/1
Hosur Road, Bommanahalli, Bangalore 560068
Phone: (+91) 80 67027066
www.rollonindia.in - info@rollonindia.in

ROLLON - JAPAN ▼

3F Shiodome Building, 1-2-20 Kaigan, Minato-ku,
Tokyo 105-0022 Japan
Phone +81 3 6721 8487
www.rollon.jp - info@rollon.jp

Consult the other ranges of products



Distributor

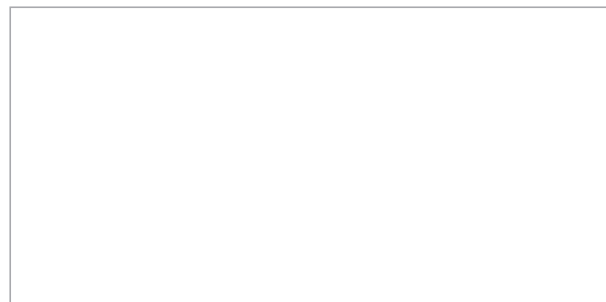

All addresses of our global sales partners can also be found at www.rollon.com

The content of this document and its use are subject to the general terms of sale of ROLLON available on the web site www.rollon.com.
Changes and errors expected. The text and images may be used only with our permission.